



UNIVERSITA' DEGLI STUDI DI BERGAMO
DIPARTIMENTO DI INGEGNERIA GESTIONALE E DELL'INFORMAZIONE^o
QUADERNI DEL DIPARTIMENTO[†]

Department of Management and Information Technology

Working Paper

Series “*Economics and Management*”

n. 02/EM – 2006

***Equity valuation using DCF:
A theoretical analysis of the long term hypotheses***

by

Lucio Cassia, Andrea Plati, Silvio Vismara

^o Viale Marconi, 5, I – 24044 Dalmine (BG), ITALY, Tel. +39-035-2052339; Fax. +39-035-562779

[†] Il Dipartimento ottempera agli obblighi previsti dall'art. 1 del D.L.L. 31.8.1945, n. 660 e successive modificazioni.

COMITATO DI REDAZIONE[§]

Series Economics and Management (EM): Stefano Paleari, Andrea Salanti

Series Information Technology (IT): Stefano Paraboschi

Series Mathematics and Statistics (MS): Luca Brandolini, Sandro Fassò

[§] L'accesso alle *Series* è approvato dal Comitato di Redazione. I *Working Papers* ed i *Technical Reports* della Collana dei Quaderni del Dipartimento di Ingegneria Gestionale e dell'Informazione costituiscono un servizio atto a fornire la tempestiva divulgazione dei risultati dell'attività di ricerca, siano essi in forma provvisoria o definitiva.

**Equity valuation using DCF:
A theoretical analysis of the long term hypotheses**

Lucio Cassia, Andrea Plati, Silvio Vismara
University of Bergamo

Working Paper

Abstract

This paper matches the sensitivity analysis of two-stage DCF models to the assumption of Long Term Steady-State. It proposes the definition of ‘Joint Sensitivity’ that measures the effect on the firm’s value of joint variations of more input parameters. The duration of the first stage of explicit forecast is one of the most important of these parameters. The assumptions leading to the definition of such length is that the company exhausts in that year its competitive advantage over the competitors and begins a period of Steady-State. So, the end of the Competitive Advantage Period, defined as the period during which the return on capital can be higher than its cost, coincides with the end of the first stage of explicit forecast of the DCF. This paper proposes an instrument (Excess Return) that measures the theoretical reliability of a valuation by verifying if the return on invested capital is asymptotically equal to its average cost.

Keywords: valuation, DCF, equity report, financial analysts
JEL: G24, G30, M49,

Contacts:

Lucio Cassia, Department of Management and Information Technology, University of Bergamo, Viale Marconi, 5 - 24044 Dalmine (BG), Tel.: +39 035 2052350, Fax: +39 02 70031063, e-mail: lucio.cassia@unibg.it.

Andrea Plati, Department of Management and Information Technology, University of Bergamo, Viale Marconi, 5 - 24044 Dalmine (BG), Tel.: +39 035 2052010, Fax: +39 035 562779, e-mail: andrea.plati@unibg.it.

Silvio Vismara, Department of Management and Information Technology, University of Bergamo, Viale Marconi, 5 - 24044 Dalmine (BG), Tel.: +39 035 2052352, Fax: +39 035 74231126, e-mail: silvio.vismara@unibg.it.

1. Introduction

When valuing a company, one of the most used techniques is the two-stage Discounted Cash Flow (DCF), where the first stage is a period of explicit forecasts while the second one assumes the cash flow to perpetually grow at a constant growth rate. The Enterprise Value is typically such that the weight of second stage (Terminal Value) turns out to be much greater than that of the first stage. Sometimes this leads to consider critic to the process of valuation only the choice of the discount rate and of the perpetual growth rate of the second stage. However, it is worthwhile to highlight that the weight of the Terminal Value is strongly influenced from the entity of the cash flow forecasted for the final year of the explicit forecast period (from which the perpetuity of the second stage is extrapolated). Therefore, the forecast of both the first and the second stage have a critical effect on the value estimated using a DCF model and a particular importance relies on the choice of the length of the period of explicit forecast.

The end of the first stage, and therefore the beginning of the implicit forecast period, must theoretically coincide with the end of a period of competitive advantage for the firm. The sources of such competitive advantage exhaust in the long term for effect of the market forces. Asymptotically in the second stage, therefore, the return on capital cannot be higher than its cost. Indeed, eventual asymptotical differences between return and cost of the invested capital would be necessarily due to an assumption of extra-profitability in the long run, in contrast with the assumption of market efficiency. In other words, the hypothesis of Steady-State, that defines the period of implicit forecast, denies the possibility of extra-profits in the long term.

The present research investigates the implications of the assumption of Steady-State. We argue that in an 'economically correct' valuation the weight of second stage in the determination of the Enterprise Value depends on the ratio between the cash flow and the invested capital for the final year of explicit forecast. In the case of valuation with a low value for such ratio, it is expected that the Terminal Value plays an important role in the determination of the Enterprise Value. In these cases, indeed, more years are needed so that the capital invested is repaid with the cash flows generated. It is therefore natural for mature companies that operate in industries with low margins to have a low value of such ratio and, consequently, to have a great part of their value depending on the cash flows generated during the second stage. Hence, their valuations are necessarily sensitive to the hypothesis of the second stage of perpetual growth. On the other hand, companies with a high value of the ratio between cash flows and capital invested should be able to repay the capital with the cash

generated in a few years after the final year of explicit forecast. Therefore, their valuation should largely rely on the discounted sum of the cash flows of the first stage and as a consequence it should be little sensitive to variations of the perpetual growth rate. Otherwise, a high importance of the second stage in the determination of the Enterprise Value would be inevitably caused from (implicit) violations of the hypothesis of Steady State. The second stage is indeed a phase of business stability in which there are no possibilities of extra-profits because it is assumed that the firm cannot systematically generate a return on capital higher than its cost.

In the light of these considerations, this paper proposes an instrument of verification of the economic coherence of the hypotheses assumed when applying a DCF model. The determination of the accuracy of a valuation, although involving several factors, has a first test bench in the hypotheses of Steady-State in second stage. To such purpose, the proposed approach defines an index of extra-profitability (namely, the Excess Return) that synthesizes and makes evident eventual anomalies in the valuation with reference to the assumption of Steady-State. Valuations that incorporate an extra-profitability demand for a particular attention, in that they could justify the Enterprise Value estimated with the assumption competitive advantage over competitors for an indefinite period.

The rest of this paper is organized as follows. In Section 2 the literature is reviewed. Section 3 is dedicated to the sensitivity analysis. Section 3 addresses the long term assumption of Steady-State, while Section 4 matches the issue on sensitivity to the Steady-State assumption. Section 5 concludes the research.

2. Literature review

The methods of firm valuation based on discounted flows receive particular attention from both theoretical studies and applications of corporate finance. Based on the specific flow considered in the discounting process, two main methods are distinguished: the Dividend Discount Model (DDM) and the Discounted Cash Flow (DCF). For the latter, there are normally two approaches: the Equity-side or Levered DCF, that considers Free Cash Flows to Equity (FCFE), and the Assets Side or Unlevered DCF, that considers the Free Cash Flows to Firm (FCFF). These methodologies of valuation are supported from a solid theoretical system. Nevertheless, the strong subjectivity of the inputs is reflected in a result - the value of the company under valuation – with an elevated level of uncertainty. In such context of uncertainty, it becomes therefore important to verify the validity of formal instruments for the

valuation of real activities (e.g. enterprises, investments or projects), with reference to the challenges placed from their implementation. The literature proposes two perspectives of validation (Figure 1): *ex-ante* and *ex-post*.

The *ex-ante* perspective draws origin from the ascertainment that forecasts (input parameters) depend largely on the expectations of the analyst. To this extent, we can identify two approaches to the study of the criticality of the inputs: sensitivity analysis and simulation. The former gives indications on which are the critical parameters and to which levels of the input corresponds an elevated sensitivity of the result. Indeed, the sensitivity analysis allows examining the elasticity of the valuation to the input parameters and, consequently, allows identifying the critical variables. Studies on this topic in the financial literature go back to the seventies (Huefner, 1971; Joy and Bradley, 1973; Whisler, 1976; Hsiao and Smith, 1978), although these studies did not directly refer to firm's valuation, but analyzed the sensitivity of two common investments appraisal techniques: the Net Present Value (NPV) and the Internal Rate of Return (IRR). These studies supply analytical instruments in order to face the uncertainty and investigate the sensitivity of output with respect to one single variable. The present paper proposes a formal approach that considers the effect of more variables altogether and defines a joint sensitivity.

The second methodology of *ex-ante* investigation is simulation. This procedure considers inputs of the valuation as aleatorial variables related to the risk and the uncertainty of the firm under valuation and treats the variables through simulation methods like the Monte Carlo. The output of the simulation is a probability distribution of the value of the firm. However, the real applicability of the simulation is quite scarce. Indeed, it requires to define the specific shape of the probability density function associated to each input variable and to supply forecasts of its "nominal value" and of the level of variability (that is, in a stochastic approach, to supply the forecast of both the expected value and the expected variance of the aleatorial variable of input).

Last, the accuracy of a valuation can be verified *ex-post* through a validation process that compares the estimated value of the valuation (for instance, the target price in the case of equity reports) with a term of reference (often the value attributed from the market to the company or the effective value of one transaction). The literature focused in the last decade on the empirical validation of the validity of the direct valuation methodologies, often confronting between themselves or also with indirect techniques. An important study in this respect is Kaplan and Ruback (1995) that demonstrates the usefulness and reliability of the DCF, in comparison with indirect methodologies. Numerous studies followed confirming the

accuracy of methodology DCF (Penman and Souginannis, 1998; Francis, Olsson and Oswald, 2000; Berkman, Bradbury and Ferguson, 2000; Gilson, Hotchkiss and Ruback, 2000).

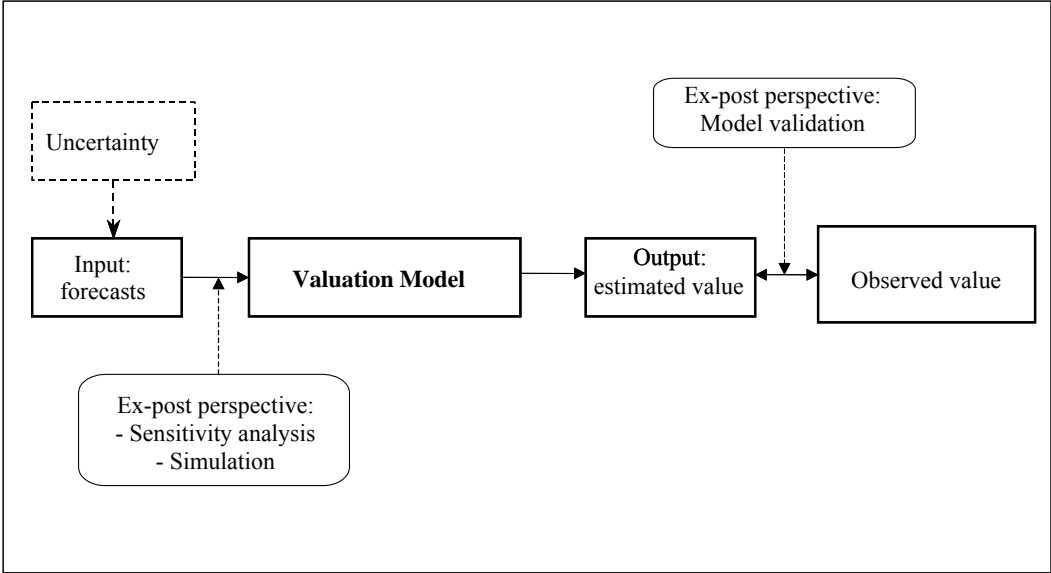

Figure 1. Different approaches to the study of the accuracy of a valuation model.

3. Joint Sensitivity: what does really matter?

The inputs of a model of valuation (for the DCF, expected cash flows and discount rate) are defined from the hypotheses of the analyst on the future of the company. Accordingly, the degree of uncertainty of the forecast of such inputs is reflected in an analogous level of uncertainty of the estimated value of the company. The sensitivity analysis with the traditional criteria allows characterizing the marginal effect of one infinitesimal variation of an input variable on the estimated firm’s value. This approach is a local analysis, in that the entity of the variation for the variable is such to make negligible the second-order effects, and it is also a mono-parametric analysis, in that the variations regard one single variable, *ceteris paribus*. In this way, the local and mono-parametric sensitivity analysis does not give information on the cross-effect among input variables. To such aim, the present paper proposes the definition of a ‘Joint Sensitivity’ that considers the effect of joint variations of more parameters.

3.1. Mono-parametric sensitivity

Using the DCF methodology, firms are considered like an investment and their value is estimated as discounted sum of the expected cash flows. Analytically, the forecast of these cash flows is resolved in the definition of a series of growth rates (Equation [1]).

$$EV = \sum_{t=1}^{\infty} \frac{FCFF_t}{(1+r)^t} = FCFF_0 \sum_{t=1}^{\infty} \frac{\prod_{i=1}^t (1+g_i)}{(1+r)^t} \quad [1]$$

According to this interpretation, the analysis of mono-parametric local sensitivity leads back to the study of the effect on the firm's value of one infinitesimal variation of a growth rate (Equation [2]).

$$S(g_k) = \frac{\partial EV / EV}{\partial g_k / (1+g_k)} \quad [2]$$

Defining the partial value of an activity, relative to the time interval that goes from year k to year k+n, as the sum of the expected discounted cash flows generated in such interval (Equation [3]), we obtain a definition of sensitivity with respect to a single rate of growth g_k (constant from the year k to the year k+n) as a function of the partial value created in that period (Equation [4], Appendix A.1).

$$EV(k, k+n) = \sum_{t=k}^{k+n} \frac{FCFF_t}{(1+r)^t} \quad [3]$$

$$S(g_k) = \frac{EV(k, \infty)}{EV} \quad [4]$$

The sensitivity of EV to g_k is given, therefore, from the ratio between the partial value of the period that goes from the year k to the infinite and the total value. A variation of g_k does not affect entirely the series of the cash flows, but only the portion that goes from year k onwards. The sensitivity analysis of the DCF model has two extremes: on one side, the analytical estimate of all the cash flows (explicit forecast) and, on the other side, the assumption of a

constant rate of growth (Gordon growth model); the two extreme cases, as well as all the intermediate solutions like the widely used two-stage model, are put in relation through the introduction of the concept of partial value. For instance, a (theoretically possible) explicit forecast model consists in a model of infinite stages of equal duration (one year), while the Gordon growth model has a single stage of infinite duration. The ‘intermediate’ models are constituted from more stages, each one with its own duration of implicit forecast period. At the base of these models there is the hypothesis of constancy of growth rates for the period of implicit forecasts (Equation [5]).

$$g_i = g_k \quad \forall i = k, \dots, k + n \quad [5]$$

The effect of the introduction of this hypothesis is that of simplifying the process of forecast of the expected cash flows: in place of n rates g_i , the only parameter to estimate turns out to be the growth rate in the period g_k . For instance, using the two-stage model, the second stage involves the estimate of only one constant growth rate g_2 for the entire period of implicit forecast of the cash flows ($g_i = g_2 \quad \forall i = T, \dots, \infty$).

Recalling from the pricing of bonds the concept of Duration as time barycentre of the expected flows (Equation [6]), the sensitivity of the firm’s value to g_k is derived imposing in the Equation [2] the Equation [5]. In this way, the sensitivity to infinitesimal variations of the constant growth rate g_k for a period of n years is expressed as in Equation [7] (proof in Appendix A.2). Figure 2 gives a graphical interpretation of the concepts hereby.

$$D_k(i, i + n) = \frac{1}{EV(i, i + n)} \sum_{t=i}^{i+n} \frac{(t-k)FCFF_t}{(1+r)^t} \quad [6]$$

$$S(g_k) = \frac{\frac{\partial EV}{\partial g_k} / EV}{\frac{\partial g_k}{\partial (1+g_k)}} = \frac{EV(k, k+n)}{EV} D_{k-1} + \frac{EV(k+n+1, \infty)}{EV} (n+1) \quad [7]$$

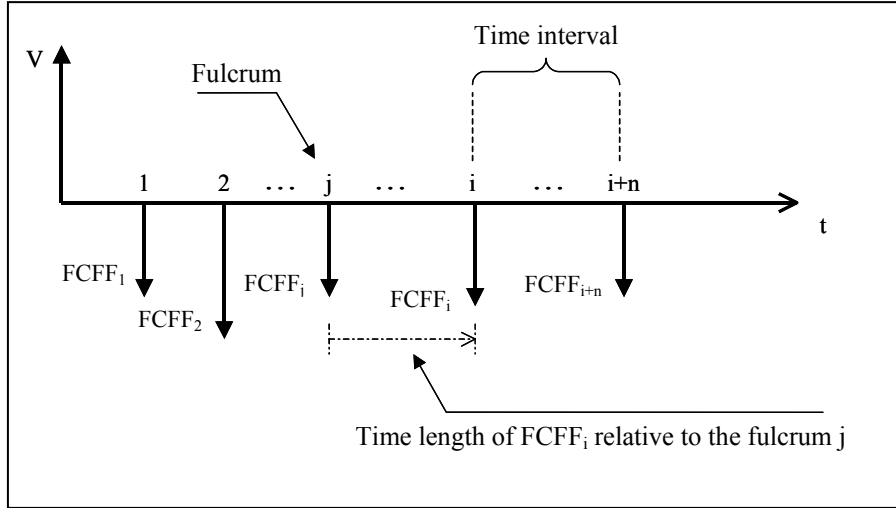

Figure 2. Stream of expected cash flows.

We can observe that the sensitivity to g_k is given from the sum of two terms. The first one is the Duration of the flows of the period of implicit forecast multiplied for the weight of such flows regarding the total value. The second one is the product between the Duration, expressed in years, of the period and the weight of the subsequent cash flows relative to the total value. Note that in the case the temporal horizon n is null (i.e. the case of explicit forecasts), the Duration is equal to one and the expression of the sensitivity is Equation [4]. From the other side, in case the horizon n stretches to infinite (e.g. the second stage of a two-stage model) there are no subsequent cash flows. In this case, the second addend of Equation [7] the Duration is null and the sensitivity only depends on the discount rate and on the long-term rate of growth g_k (equation [8]).

$$D_{k-1} = \frac{r+1}{r-g_k} \quad [8]$$

3.2. (Multi-parametric) Joint Sensitivity

We now move to consider the effect on firm's value of a joint variation in the input of the model. By expressing the expected series of cash flows in terms of series of growth rates (equation [1]), the parameters of the sensitivity analysis are aggregated in a single matrix $G=[g_i]$. In order to combine the mono-parametric sensitivities for each growth rate g_i , we define a coefficient of Joint Sensitivity (JS) defined as the square root of the sum of the quadratic sensitivity relative to all the inputs of the vector G (Equation [9]).

$$JS(G) = \sqrt{\sum_{g_{i,n} \in G} S(g_{i,n})^2} \quad [9]$$

The Joint Sensitivity measures the effect on the firm's value of small (aleatorical and independent) variations in the input parameters. The definition of JS appears of immediate application with reference to the two-stage model, for which there are only two growth rates: elevated in the first period (g_1) and stable in the second period of implicit forecast (g_2). In such conditions, we can express JS as a function of the mono-parametric sensitivity relative to g_1 and g_2 (equation [10]):

$$JS(G) = \sqrt{S(g_1)^2 + S(g_2)^2} \quad [10]$$

The mono-parametric sensitivity to the two growth rates is obtained imposing in the Equation [7] the constrain $g_k = g_{0,T} = g_1$ for the first (equation [11]) and the constrain $g_k = g_{T+1,\infty} = g_2$ for the second stage (equation [12]).

$$S(g_1) = \frac{EV(1,T)}{EV} D_0(1,T) + \frac{EV(T+1,\infty)}{EV} T \quad [11]$$

$$S(g_2) = \frac{EV(T+1,\infty)}{EV} D_T(T+1,\infty) \quad [12]$$

The sensitivity to the growth rate of the first period (g_1) is given from the sum of two terms: the first one is the Duration of the flows relative to the first stage (Duration of the first stage), multiplied for the weight of that stage relative to the total value; the second is T times the weight of the second stage (Terminal Value) relative to EV. Therefore, this member of JS depends (although partly) also on the long term rate of growth (g_2). The sensitivity to g_2 is instead expressed as the product of two members: the Duration of second stage and its weight in relation to total value EV. The first component can be expressed as a function of the cost of capital and of the long term rate of growth, as expressed in the equation [8]. In this way, it becomes explicit that the Duration of the second stage, and therefore the sensitivity to g_2 , does not depend on the parameters of the first stage (i.e. g_1 and T), but only on the discount rate and on the perpetual growth rate. In particular, for a constant discount rate, the sensitivity to

g_2 will grow quickly when g_2 approaches the discount rate, and the denominator of the Duration $(r-g_2)$ is close to zero.

The Joint Sensitivity is expressed as a standardized sum (Equation [10]) of the two mono-parametric sensitivities. The member $S(g_1)$ is scarcely correlated to the rate g_2 , while the member $S(g_2)$ depends mainly on g_2 and introduces a vertical asymptote in correspondence of the g_2 equal to the discount rate. Ceteris paribus (i.e. for constant values of T , g_1 and r) is possible to graph these considerations, by tracing the values of $S(g_1)$, $S(g_2)$ and $JS(G)$ relative to g_2 . Figure 2 gives an example of such relations under opportune hypotheses. We can see that $JS(G)$ is almost equal to $S(g_1)$ for low values of g_2 , while the influence of $S(g_2)$ increases quickly to the increase of g_2 and, for high values of the latter, the effect of g_1 appears negligible and JS turns out to be close to $S(g_2)$.

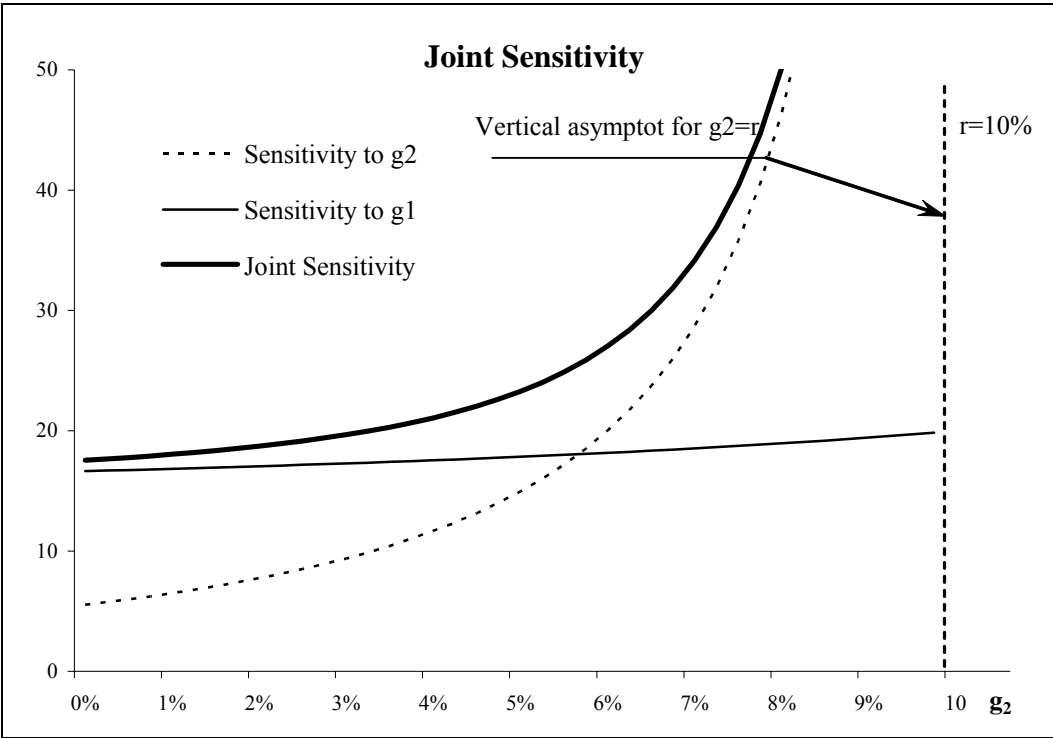

Figure 3. Sensitivity to g_1 and g_2 and joint sensitivity for the two-stage model.

In this graph we assume the following values for the parameters: $g_1=20%$, $r=10%$ e $T=20$ years.

In order to identify the contribution of the two inputs to JS , we define two adimensional indexes that indicate the percentage of JS due to the rate of growth of first (k_1) and of the second (k_2) stage of the DCF (Equation [13]).

$$k_1 = \frac{S(g_1)^2}{SC(G)^2} \qquad k_2 = \frac{S(g_2)^2}{SC(G)^2} \qquad [13]$$

Note that the weight of the first stage on JS (k_1) strongly diminishes for low values of T , while on the contrary k_2 acquires importance for high values of T (otherwise its effect is negligible). The length of the first stage plays, therefore, a fundamental role in the division of JS between the two stages (in particular, in the example of Figure 3 it is used a particularly high length of the first stage: 20 years). The length of the first stage constitutes the parameter that more conditions $S(g_1)$ since it represents the limit of the possible values that it can assume. Accordingly the definition of the length of the first stage is one of the most important parameters of a DCF model. Indeed, as the extension of such period decreases, the weight of the high rate of growth (k_1) on JS strongly reduces (Figure 4). In this way, JS tends to coincide with the mono-parametric sensitivity $S(g_2)$, while g_1 only acquires importance for high values of T .

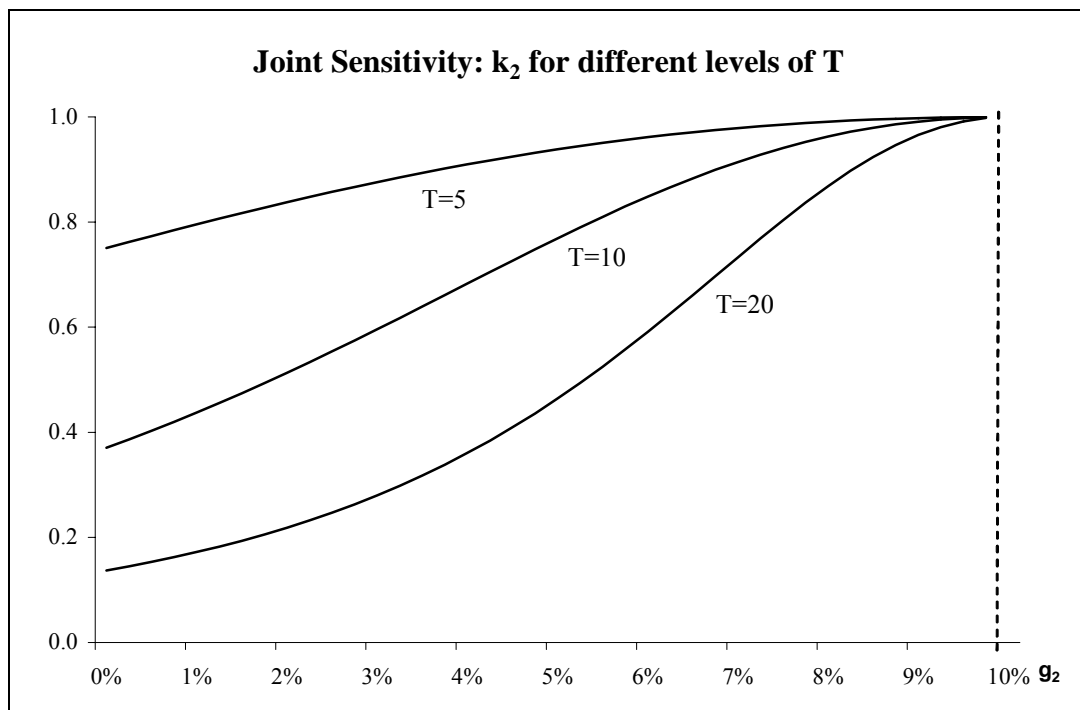

Figure 4. Component of Joint Sensitivity due to g_2 , as a function of the length of the first stage. Other values of the parameter are assumed as in Figure 3: $g_1=20\%$ e $r=10\%$.

4. Assumption of Long Term Steady State: is it really respected?

According to the assets-side of the DCF, the firm's value is calculated as the discounted sum of the expected cash flows generated from the invested capital, discounted to a rate that takes into account the remuneration for all the categories of holders of the firm (usually estimated in terms of WACC, Weighted Average Cost of Capital, Equation 14).

$$EV_t = \sum_{i=1}^{\infty} \frac{FCFF_{t+i}}{(1+WACC)^i} \quad [14]$$

Since it is focused on cash flows, the DCF does not reflect directly the hypotheses on the operating performances of the firm in every single year of forecast. As a consequence, the assumptions at the base of the valuation turn out to be scarcely controllable from an economic standpoint. The problem is more important as far as the sustainability of the competitive advantage and, in general terms, the forecast of the parameters in the long period, are responsible of a great fraction of the value. In such contexts, an improvement in terms of controllability is obtained leading back the DCF model to the logic of value generation founded on the notion of Economic Profit (or Residual Income). The Economic Profit (EP) is typically defined as the difference between the return on capital and its cost (Equation [15]).

$$EP_t = (ROIC_t - WACC) \cdot IC_{t-1} \quad [15]$$

where ROIC is the expected rate of return on new investments given from the ratio between the net operating profit after taxes and the invested capital: $ROIC_t = NOPAT_t / IC_{t-1}$.

Coherently with Feltham and Ohlson (1995), the variation of operating capital invested in the company is equal to the difference between the net operating income and the cash flow available for the investors. This relation is known as 'Operating Assets Relation' (Equation [16] and Figure 5).

$$\Delta IC_t = NOPAT_t - FCFF_t \quad [16]$$

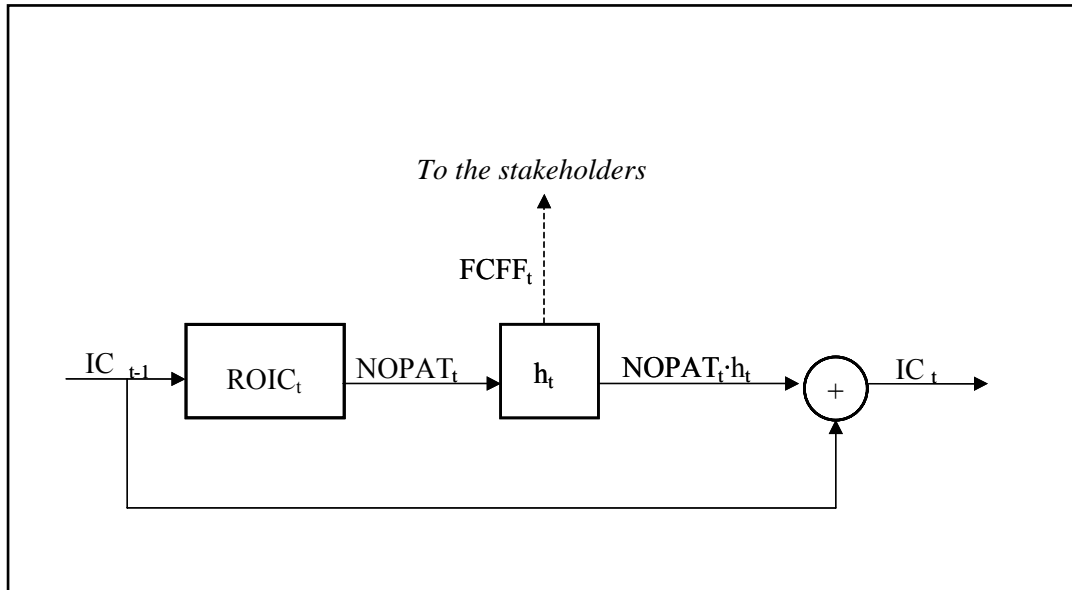

Figure 5. Operating Assets Relation.

As shown in Appendix A.3, we can transform the equation of DCF model (Equation [14]) to make explicit the generation of economic value rather than the distribution of monetary flows: Equation [17] defines the model of the Economics Profits (EP), where the Enterprise Value is given from the sum between the book value of its capital invested and the present value of the expected Economic Profits.

$$EV_t = IC_t + \sum_{i=1}^{\infty} \frac{EP_{t+i}}{(1+WACC)^i} \quad [17]$$

The DCF model and the EP model give identical results as far as they underline the identical hypotheses on the future of the company under valuation (such condition demands for a limitless horizon of forecasting). The advantage in models focused on the generation of economic value is in terms of a smaller sensitivity of the result to the input parameters. In particular, the assumptions for the definition of the Terminal Value become less ‘demanding’ compared to what is needed for the DCF model. Numerous studies give empirical support the approach based on the definition of Economic Profits, often called Residual Income Model (Penman and Sougiannis, 1998; Francis et al., 2000).

Contrarily to the equation of the traditional DCF model [Equation 14], that does not depend on how the operating assets are measured, Equation 17 is necessarily tied to the accounting principles used for the calculation of the capital invested and of the Economic Profits.

Nevertheless, the equality between the Equation 14 and Equation 17 is not conditioned from the particular accounting method but it is guaranteed exclusively from the Equation 16. To the aims of this paper, the equivalence between the DCF model and EP model is fundamental in that it defines, on the base of theoretical considerations, one metric for the validation of the coherence of the hypotheses at the base of the definition of the Terminal Value of the DCF model. The next paragraph formally defines the concept of Steady-State.

4.2 Profitability and cost of capital under the assumption of Long Term Steady State

The growth rate of the operating income g_t^{NOPAT} can be expressed in function of the profitability of the capital invested, differentiating the investments in place at the beginning of the year and the new investments of the period (proof in Appendix A.4).

$$g_t^{NOPAT} = ROIC_t^{\text{marg}} h_{t-1} + g_t^{\text{ROICold}} \quad [18]$$

where $ROIC_t^{\text{marg}}$ is the incremental return on new invested capital and g_t^{ROICold} is the variation of the return on investments in place at the beginning of year t-1.

The use of the simple formula of the perpetuity for the calculation of the Enterprise Value in the implicit forecast period is based on the hypothesis that in that stage the company has reached a condition Steady-State. Under such assumption, it is correct to model the growth of the company as a function of a single stable long-term growth rate g_2 . The Steady-State is analytically defined by the imposition of three conditions:

i) The incremental return on new invested capital is constant during the Steady-State.

$$ROIC_{T+i}^{\text{marg}} = ROIC^{\text{marg}} = \text{cost} \quad [19]$$

ii) The investment rate (defined as net investment over operating profits) is constant during the Steady-State and it is equal to the investment rate at the final year of explicit forecast.

$$h_{T+i} = h_T = \text{cost} \quad [20]$$

iii) The incremental return on new invested capital is constant, so the average return on invested capital varies in the second stage only as a consequence of new investments.

$$g_{T+i}^{\text{ROICold}} = 0 \quad [21]$$

The conditions imposed for the Steady-State allow to express the growth rate of the operating income as a function of only two variables: the marginal profitability $ROIC^{\text{marg}}$ and the investment rate h_T . Moreover, since the investment rate is constant in the second stage, the growth of the operating income coincides with the growth rate of the cash flows g_2 (Equation [22]).

$$g_{T+i}^{\text{NOPAT}} = ROIC^{\text{marg}} h_T = g_2 \quad [22]$$

Equation [23] expresses the return on invested capital (ROIC) in the second stage: it depends only on the conditions estimated for the company at the final year of the explicit forecast period and from the value of the incremental return on new invested capital (proof in Appendix A.5).

$$ROIC_{T+i} = \frac{ROIC_T (1 + h_T ROIC^{\text{marg}})^i}{1 + \sum_{j=1}^i h_T ROIC_T (1 + h_T ROIC^{\text{marg}})^{j-1}} \quad [23]$$

Appendix A.6 demonstrates that for a horizon of observation that becomes extremely large, and for a positive investment rate h_T , the return on invested capital approaches the incremental return on new invested capital. For h_T equal to zero, the return on invested capital is constant and equal to that at year T, while if h_T is negative, the return on invested capital growth unlimitedly at the growth of the observation horizon.

$$\lim_{i \rightarrow \infty} ROIC_{T+i} = ROIC^{\text{marg}} \quad [24]$$

Therefore, assuming a positive investment strategy, incremental return on new invested capital represents the profit of the company in the long run. Beside, the next step is to make

explicit that assumption of Steady-State impose the absence of a sustainable competitive advantage in the long run. An important contribution is given by Mauboussin and Johnson (1997) by identifying the Competitive Advantage Period (CAP) as the element of connection between the application and the theory of the DCF model. The CAP is defined as the period during which the return on capital can be higher than its cost. The authors think that, when defining the extension of the implicit forecast period, the analysts do not always respect the Competitive Advantage Period, with the effect of passing on to the Terminal Value a part of the economic value and, consequently, with the risk of compromising the reliability of the valuation. Coherently with Mauboussin and Johnson (1997), we assume for the implicit forecast period that the return on capital has to be equal to its cost (Equation [25]).

$$ROIC^{\text{marg}} = WACC \quad [25]$$

In this way, we take into account that is not coherent to assume that the company can be able to maintain limitless a competitive advantage, because of the effect of the competitive forces that gradually equalize the return on capital and the cost of capital. The equation [25] does not exclude the possibility to have a generation of economic value in the implicit forecast period. It simply demands that as the observation horizon increases the difference between return on cost of capital (that generates the Economic Profits) decreases asymptotically. From Equation [18] and Equation [25], we derive the ‘ideal’ growth rate of the cash flows for the implicit forecast period (Equation [26]).

$$g_2^{\text{Ideal}} = WACC \cdot h_T \quad [26]$$

4.3 Long Term Steady State and Sensitivity

As noted in the previous paragraphs, the duration of the first stage of explicit forecast assume a fundamental role in the DCF model. The assumptions leading to the definition of such length T of the explicit forecast period is that the company exhausts in that year the possibilities of ‘extra-growth’ for effect of a competitive advantage, and subsequently the growth of its cash flows is at a constant rate that is necessarily inferior than the growth rate of the economy (otherwise in the long run the company would ‘incorporate’ all the economy). In this paragraph, we investigate if effectively the end of the implicit forecast period coincides with the beginning of the Steady-State. Indeed, the Steady-State assumption implies that the

return on invested capital (ROIC) is equal to its average cost (WACC), as expressed in Equation [25]. Eventual differences between these figures would be instead generated by opportunities of extra-profitability in the long term, in contrast with the principles of efficiency of the market that states the progressive erosion of the advantage over the competitors. These considerations induce to the definition of an index of long run extra-profitability (Excess Return, ER). ER is defined as the difference between return and cost of capital, scaled by the cost of capital (Equation [27]). The hypothesis of long run Steady-State denies the possibility of ER different from zero. Indeed, positive values of ER would imply that the company is able to pursue extra-profits for a limitless period, that is to say that it holds a competitive advantage for an indefinite period

$$ER = \frac{ROIC^{marg} - WACC}{(1 + WACC)} \quad [27]$$

From Equation [8], Equation [12], Equation [18] and Equation [27] prove that the Duration of the second stage can be expressed as a function of two terms (Equation [28]):

- coefficient of liquidity, defined as the ratio between the cash flow at the final year of the explicit forecast period ($FCFF_T$) and the net capital invested at the same year (IC_T);
- extra-profitability member due to the eventual difference in Steady-State between the level of profitability of the company and its cost of capital (ER, Equation [28]).

$$D_T(T + 1, \infty) = \frac{1 + FCFF_T / IC_T}{FCFF_T / IC_T - ER} \quad [28]$$

As can be inferred from Equation [12], the Duration of the second stage (Equation [28]) is directly related to the sensitivity of the valuation to the long term growth rate of the cash flows ($S(g_2)$). The sensitivity is indeed equal to the Duration times the weight of the Terminal Value relative to the Enterprise Value. Therefore, like the Duration, the sensitivity to g_2 depends on the two members: liquidity ($FCFF_T/IC_T$) and extra-profitability (ER). Figure 6 graphs such relation between the Duration (and, therefore, the sensitivity) of the second stage and the ‘liquidity’ and extra-profitability levels. The values of the Duration are, indeed, expressed as a function of the coefficient of liquidity and parameterized to the levels of Excess Return (ER).

An economically correct valuation identifies the long term stage of implicit forecast of Steady-State in which there are no possibilities of extra-profits ($ER=0$). At a theoretical level, indeed, the Excess Return should not to be distant from the ideal null level, because it is assumed that the company cannot systematically generate a return on capital higher than its cost. Valuations that assume wide positive values of ER are therefore of difficult justification from an economic perspective since the value of the company turns out to depend on an improbable business ability to maintain a competitive advantage on the competitors for an indefinite period. Valuations that respect the economic theory are therefore graphically expressed from the first contour line, in correspondence of a null value for the Excess Return. It is worthwhile to note that the economic coherence of a valuation does not necessarily imply a low sensitivity to g_2 . Indeed, in case of valuations with small values of the coefficient of liquidity, it appears coherent that the Duration of the second stage is elevated, since it takes a number of years for the company to have the cash flows to repay the capital invested at the year T. In these cases (like case A in Figure 6), therefore, the elevated weight of the Terminal Value in the determination of the Enterprise Value and, consequently, the high sensibility to g_2 , does not appear in contradiction with the economic hypotheses implicit in the assumption of Steady-State in the long term. On the contrary, high levels of the Duration of the second stage, associated to high values of the coefficient of liquidity implicitly indicates the assumption of ability to generate extra-profits for a limitless period. For instance, the case B in Figure 6 has the same Duration of the case A, but in the former the sensitivity is mainly due to an implicit assumption of extra-profitability in the long-run. Therefore, case B is not coherent with the economic hypothesis at the base of the definition of long term Steady-State. Under the hypothesis of Steady-State, the coefficient of liquidity depends on both the analyst's forecasts for the first stage and the characteristics of the company under valuation (in primis, the phase of its life cycle and the profitability of the industry in which it operates). It is therefore somehow natural for mature companies operating in industries with low marginalities to show low values of such coefficient of liquidity and therefore a high level of sensibility of their Enterprise Value to the perpetual growth rate: a great part of their value depends, indeed, from the cash flows generated in the second stage. Vice versa, risky companies, with a high cost of capital, should have a lower sensitivity to g_2 .

In order to evaluate the reliability of a valuation, the member due to the Excess Return is more meaningful than the simple sensitivity because it isolates the effect of the eventual incoherencies implicit in the assumption of long term Steady State.

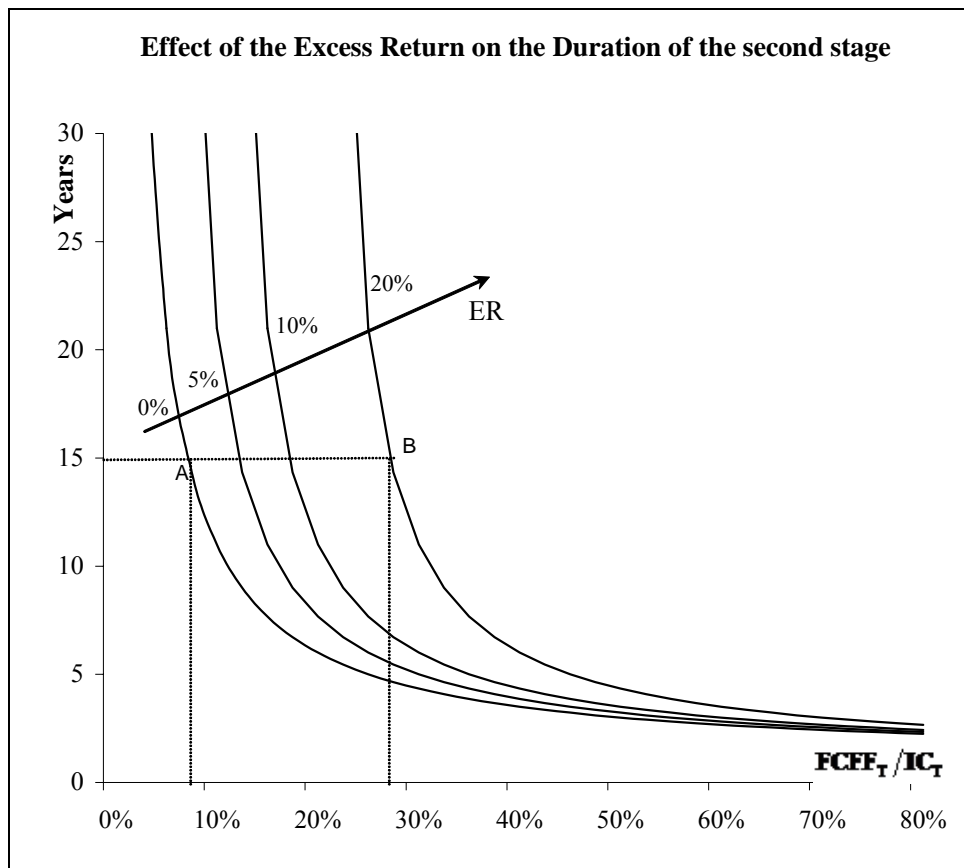

Figure 6. Duration of the second stage as a function of the coefficient of liquidity $FCFF_T/IC_T$.
Contour lines are parameterized to the values given to the level of extra-profitability ER.

The formal accuracy of a valuation requests the Excess Return to be close to zero. The advantage of the ER approach is that it is a parameter that synthesizes eventual theoretical distortions introduced in the valuation. There could be many possible explanations of an Excess Return. For instance, the period of explicit forecast could not be sufficiently long in order to exhaust the sources of competitive advantage. This can be the case of companies with a high investment policy during the year preceding the valuation: in such cases the level of amortizations grows quickly in the first years of forecast. It is therefore necessary in these cases to pay attention not to extend the benefits of the investment also in the long term period of Steady State. To this extent, the ER verifies if the phase of transition from the first to the second stage has been set up correctly. Positive ERs can also be caused from an excessively optimistic forecast of the expected operating income for the final year T with respect the cost of capital. Finally, another cause of positive ERs could simply be the assumption of a high value of the perpetual growth rate of cash flows.

5. Conclusions

This paper matches the sensitivity analysis of two-stage DCF models to the assumption of Long Term Steady-State. First, it proposes the definition of ‘Joint Sensitivity’ that measures the effect on the firm’s value of joint variations of more input parameters. Predictably, the sensitivity analysis shows that Enterprise Value is mainly sensitive to variations of the perpetual growth rate of the second stage. Besides, when valuing a company using a two-stage DCF model, the duration of the first stage of explicit forecast assumes a fundamental role. The assumptions leading to the definition of such length is that the company exhausts in that year the possibilities of ‘extra-growth’ for effect of competitive advantage. However, the assumptions at the base of the valuation are not immediately controllable from an economic standpoint: since it is focused on cash flows, the DCF does not reflect directly the hypotheses on the operating performances of the firm in every single year of forecast. The problem is more important as far as the second stage is responsible of a great fraction of the estimated Enterprise Value. In such contexts, an improvement in terms of controllability of the process of valuation is obtained leading back the DCF model to the logic of value generation founded on the notion of Economic Profit (or Residual Income).

In order to make explicit that assumption of Steady-State, we refer to the definition Competitive Advantage Period (CAP) proposed by Mauboussin and Johnson (1997) as the element of connection between the application and the theory of the DCF model. The CAP is defined as the period during which the return on capital can be higher than its cost. When defining the extension of the implicit forecast period, the analysts do not always respect the Competitive Advantage Period, with the effect of passing on to the Terminal Value a part of the economic value and, consequently, with the risk of compromising the reliability of the valuation. To this extent, this paper proposes an instrument that measures if the return on invested capital is asymptotically equal to its average cost (Excess Return should ideally be equal to zero). The importance of the Terminal Value depends essentially on two parameters: the entity of the cash flow of the final year of the first stage and the perpetual growth rate of the second stage. If the forecast of the final cash flow is small relative to the capital invested, it is natural that the valuation largely depends on the assumptions on the second stage, as it will take many years to the cash flows to repay the capital invested. In these cases, the sensitivity of the Enterprise Value to the long term growth rate appears a normal characteristic of the DCF that does not depend on the specific implementation by the analyst. To the contrary, if the ratio between the cash flow and the capital invested at the end of the period of

explicit forecast is high, the estimated Enterprise Value should not necessarily rely excessively on the second stage. However, assumptions on the Steady-State are critical as an equity report could implicitly preview a return on capital that is asymptotically higher than its cost, implying the violation of the assumption of absence of competitive advantage in the long term. For this reason, the difference between return and cost of capital in the long run constitutes a useful instrument of verification of the economic coherence of the hypothesis of Steady-State at the base of the definition of the second stage. Valuations that contemplate substantial possibilities of extra-profit in long period are not very realistic, since they justify the estimated value of the company with its ability to preserve a competitive advantage on the contenders for an indefinite period.

Further researches are needed to empirically validate the concept of Excess Return proposed in this paper. To this extent, the analysis of the Excess Return could be framed in a study that compares target prices to real stock prices after the publication of a sample of the equity reports.

References

- Berkman H., Bradbury M.E., Ferguson J., 2000, "The Accuracy of Price-Earnings and Discounted Cash Flow Methods of IPO Equity Valuation", *Journal of International Financial Management and Accounting* 11:2, pp. 71-83.
- Francis J., Olsson P., Oswald D.R., 2000, "Comparing the Accuracy and Explainability of Dividend, Free Cash Flow, and Abnormal Earnings Equity Value Estimates", *Journal of Accounting Research* 38:1, pp. 45-70.
- Gilson S.C., Hotchkiss E.S., Ruback R.S., 2000, "Valuation of Bankrupt Firms", *Review of Financial Studies* 13:1, pp. 43-74.
- Hsiao F.S., Smith W.J., 1978, "An Analytic Approach to Sensitivity Analysis of the Internal Rate of Return Model", *Journal of Finance* 33:2, pp. 645-649.
- Huefner R.J., 1971, "Analyzing and Reporting Sensitivity Data", *Accounting Review* 46:4, pp. 717-732.
- Joy O.M., Bradley J.O., 1973, "A Note on Sensitivity Analysis of Rates of Return", *Journal of Finance* 28:5, pp. 1255-1261.
- Kaplan S.N., Ruback R.S., 1995, "The Valuation of Cash Flow Forecasts: An Empirical Analysis", *Journal of Finance* 50:4, pp. 1059-1093.
- Mauboussin M., Johnson P., 1997, "Competitive Advantage Period: The Neglected Value Driver", *Financial Management* 26: 2, pp. 67-74.
- Penman S., Sougiannis T., 1998, "A Comparison of Dividend, Cash Flow, and Earnings Approaches to Equity Valuation.", *Contemporary Accounting Research* 15:3, 343:84.
- Smith W. J., 1978, "Sensitivity Analysis of Rates of Return: Comment", *Journal of Finance* 33:5, pp. 1457-1460.
- Whisler W.D., 1976, "Sensitivity Analysis of Rates of Return", *Journal of Finance* 31:1 pp. 63-69.

Appendixes

A.1. Mono-parametric sensitivity in terms of partial Enterprise Value

From Equation [1]:

$$\frac{\partial EV}{\partial g_k} = FCFF_0 \frac{\partial}{\partial g_k} \left[\sum_{t=1}^{\infty} \frac{\prod_{i=1}^t (1+g_i)}{(1+r)^t} \right]$$

$$\frac{\partial EV}{\partial g_k} = FCFF_0 \sum_{t=k}^{\infty} \frac{\partial \left(\prod_{i=1}^t (1+g_i) \right)}{(1+r)^t} = FCFF_0 \sum_{t=k}^{\infty} \frac{\prod_{i=1}^t (1+g_j)}{(1+r)^t} = \frac{FCFF_0}{(1+g_k)} \sum_{t=i}^{\infty} \frac{\prod_{i=1}^t (1+g_i)}{(1+r)^t}$$

From Equation [3]:

$$\frac{\partial EV}{\partial g_k} = \frac{EV(k, \infty)}{(1+g_k)}$$

Therefore:

$$S(g_k) = \frac{V(k, \infty)}{V}$$

A.2. Mono-parametric sensitivity in terms of Duration

$$\frac{\partial EV}{\partial g_{j,n}} = \sum_{i=1}^{\infty} \frac{\partial EV}{\partial g_i} \frac{\partial g_i}{\partial g_{j,n}}$$

The partial derivatives of g_i with respect to $g_{j,n}$ are equal to zero if i is not in the period of analyses that spans from year j to $j+n$; otherwise the partial derivatives are equal to one:

$$\begin{cases} \frac{\partial g_i}{\partial g_{j,n}} = 1 & \text{per } i = j, \dots, j+n \\ \frac{\partial g_i}{\partial g_{j,n}} = 0 & \text{per } i < j \vee i > j+n \end{cases}$$

In this way, it is possible to simplify the derivative:

$$\frac{\partial EV}{\partial g_{j,n}} = \sum_{i=j}^{j+n} \frac{\partial V}{\partial g_i} \frac{\partial g_i}{\partial g_{j,n}} = \sum_{i=j}^{j+n} \frac{\partial EV}{\partial g_i}$$

Using such equation in the definition of sensitivity (Equation [2]):

$$S(g_{j,n}) = \sum_{i=j}^{j+n} \frac{\frac{\partial EV}{\partial g_i} / EV}{(1 + g_{j,n})}$$

The terms of the sum are the coefficient of sensitivity to g_i , therefore:

$$S(g_{j,n}) = \sum_{i=j}^{j+n} S(g_i)$$

From Equation [4]:

$$S(g_{j,n}) = \sum_{i=j}^{j+n} \frac{EV(i, \infty)}{EV}$$

The partial value $EV(i, \infty)$ can be broken up into two addends: the value of the cash flows in the period $[i, j+n]$ and that of the flows in the period $[j+n+1, \infty]$:

$$EV(i, \infty) = EV(i, j+n) + EV(j+n+1, \infty)$$

$$S(g_{j,n}) = \frac{1}{EV} \sum_{i=j}^{j+n} EV(i, j+n) + \frac{EV(j+n+1, \infty)}{EV} (n+1)$$

From Equation [3]:

$$S(g_{j,n}) = \frac{1}{V} \sum_{t=j}^{j+n} \frac{(t-j+1)FCFF_t}{(1+r)^t} + \frac{EV(j+n+1, \infty)}{EV} (n+1)$$

From Equation [6]:

$$S(g_{j,n}) = \frac{EV(j, j+n)}{EV} D_{j-1}(j, j+n) + \frac{EV(j+n+1, \infty)}{EV} (n+1)$$

A.3. Equivalence between DCF model and EP model

Using in Equation [14] the definition of cash flows derived from the operative assets relation $FCFF_t = NOPAT_t - \Delta IC_t$, we obtain:

$$EV_t = \sum_{i=1}^{\infty} \frac{NOPAT_{t+i} - \Delta IC_{t+i}}{(1+WACC)^i}$$

Using the definition of Economic Profit, we obtain:

$$EV_t = \sum_{i=1}^{\infty} \frac{EP_{t+i} + WACC \cdot IC_{t+i-1} - \Delta IC_{t+i}}{(1+WACC)^i} = \sum_{i=1}^{\infty} \frac{IC_{t+i-1}(1+WACC)}{(1+WACC)^i} + \sum_{i=1}^{\infty} \frac{IC_{t+i}}{(1+WACC)^i} + \sum_{i=1}^{\infty} \frac{EP_{t+i}}{(1+WACC)^i}$$

$$EV_t = IC_t + \sum_{i=1}^{\infty} \frac{EP_{t+i}}{(1+WACC)^i}$$

A.4. Growth rate of NOPAT

We distinguish the contribute of the past and of the new investments:

$$g_t^{NOPAT} = \frac{NOPAT_t - NOPAT_{t-1}}{NOPAT_{t-1}} = \frac{IC_{t-2}ROIC_t^{old} + \Delta IC_{t-1}ROIC_t^{marg} - IC_{t-2}ROIC_{t-1}}{NOPAT_{t-1}}$$

$$g_t^{NOPAT} = \frac{ROIC_t^{old} - ROIC_{t-1}}{ROIC_{t-1}} + \frac{\Delta IC_{t-1}}{NOPAT_{t-1}} ROIC_t^{marg} = g_t^{ROIC^{old}} + h_{t-1}ROIC_t^{marg}$$

A.5. Implications on ROIC of the assumption of Long Term Steady State

As the profitability of the past investments is constant, we obtain:

$$ROIC_{t+i} = \frac{IC_{t+i-2}ROIC_{t+i-1} + \Delta IC_{t+i-1}ROIC^{marg}}{IC_{t+i-1}} = \frac{IC_{t+i-2}ROIC_{t+i-1} + IC_{t+i-2}h_T ROIC_{t+i-1}ROIC^{marg}}{IC_{t+i-2}(1 + h_T ROIC_{t+i-1})}$$

$$ROIC_{t+i} = \frac{ROIC_{t+i-1}(1 + h_T ROIC^{marg})}{1 + h_T ROIC_{t+i-1}}$$

$$ROIC_{t+i} = \frac{ROIC_{t+i-2}(1 + h_T ROIC^{marg})^2}{1 + h_T ROIC_{t+i-2} + h_T ROIC_{t+i-2}(1 + h_T ROIC^{marg})}$$

For $t=T$:

$$ROIC_{T+i} = \frac{ROIC_T(1 + h_T ROIC^{marg})^i}{1 + \sum_{j=1}^i h_T ROIC_T(1 + h_T ROIC^{marg})^{j-1}}$$

A.6. Asymptotic properties of ROIC under the assumption of Long Term Steady State

The denominator of the limit is the geometric series:

$$ROIC_{T+i} = ROIC_T \cdot \left[\frac{1}{(1 + h_T ROIC^{marg})^i} + \frac{h_T ROIC_T}{1 + h_T ROIC^{marg}} \sum_{j=1}^i (1 + h_T ROIC^{marg})^{j-i} \right]^{-1}$$

$$ROIC_{T+i} = ROIC_T \cdot \left[\frac{1}{(1 + h_T ROIC^{marg})^i} + \frac{h_T ROIC_T}{1 + h_T ROIC^{marg}} \sum_{k=0}^{i-1} \frac{1}{(1 + h_T ROIC^{marg})^k} \right]^{-1}$$

$$\lim_{i \rightarrow \infty} ROIC_{T+i} = \lim_{i \rightarrow \infty} \left[\frac{h_T}{1 + h_T ROIC^{marg}} \sum_{k=0}^{i-1} \frac{1}{(1 + h_T ROIC^{marg})^k} \right]^{-1} = ROIC^{marg}$$