

(19)



(11)

EP 3 419 917 B1

(12)

EUROPEAN PATENT SPECIFICATION

(45) Date of publication and mention of the grant of the patent:
25.12.2019 Bulletin 2019/52

(51) Int Cl.:
B65D 85/804 (2006.01)

(21) Application number: **17717228.5**

(86) International application number:
PCT/IB2017/051141

(22) Date of filing: **27.02.2017**

(87) International publication number:
WO 2017/145135 (31.08.2017 Gazette 2017/35)

(54) A CAPSULE FOR PRODUCING A BEVERAGE

KAPSEL ZUR HERSTELLUNG EINES GETRÄNKES

CAPSULE POUR LA PRODUCTION D'UNE BOISSON

(84) Designated Contracting States:
AL AT BE BG CH CY CZ DE DK EE ES FI FR GB GR HR HU IE IS IT LI LT LU LV MC MK MT NL NO PL PT RO RS SE SI SK SM TR

(74) Representative: **Giannini, Manuela et al**
Studio Torta S.p.A.
Via Viotti, 9
10121 Torino (IT)

(30) Priority: **26.02.2016 IT UB20161103**

(56) References cited:
EP-A1- 0 293 772 EP-A1- 2 133 285
EP-A1- 2 808 269 WO-A1-2007/114685
WO-A1-2012/035012 WO-A1-2012/121597
WO-A1-2014/202105 WO-A1-2015/124526
WO-A1-2015/124534 ES-A2- 2 446 641

(43) Date of publication of application:
02.01.2019 Bulletin 2019/01

(73) Proprietor: **Gruppo Gimoka S.R.L.**
20090 Trezzano Sul Naviglio (IT)

(72) Inventor: **D'URSO, Gianluca Danilo**
23014 Andalo Valtellino (IT)

EP 3 419 917 B1

Note: Within nine months of the publication of the mention of the grant of the European patent in the European Patent Bulletin, any person may give notice to the European Patent Office of opposition to that patent, in accordance with the Implementing Regulations. Notice of opposition shall not be deemed to have been filed until the opposition fee has been paid. (Art. 99(1) European Patent Convention).

Description**Technical field**

[0001] The present invention relates to a capsule for preparing a beverage. In particular, the present invention relates to a capsule comprising a cup-shaped body, which is adapted to contain a dose of a substance to be brewed, has a longitudinal axis and comprises a lateral wall coaxial with the axis, a bottom wall, and a tubular appendage extending from the bottom wall towards the inside of the capsule and defining a beverage outflow channel. The capsule is also provided with a cover to close the cup-shaped body, and the tubular appendage has a first axial end facing the cover and defining the inlet of the beverage outflow channel, and a second axial end defining the outlet of the beverage outflow channel.

State of the art

[0002] Above-described capsules are known, for example, from EP 0 057 671 B1 and WO 2015/124526.

[0003] As is known, the main function of the tubular appendage in this type of capsule is to improve the so-called pre-brewing phase by a greater diffusion of the brewing fluid in the substance to be brewed; in fact, the fluid supplied into the capsule through the cover is forced to follow a descending and ascending winding path before flowing out of the capsule through the tubular appendage.

[0004] To further enhance this substance pre-brewing phase and, at the same time, filter the delivered beverage, different solutions are known which are based on increasing hydraulic resistance along the beverage output path. This result is achieved, for example, by reducing the flow section of the whole beverage outflow channel, as in EP 0 057 671 B1, or only of the inlet end, as in WO 2015/124526, where the beverage is supplied to the beverage outflow channel through one or more holes or slots formed on the wall of the tubular appendage.

[0005] However, these solutions suffer from a few drawbacks, such as, having a limited flexibility in terms of control of the pressure inside the capsule, introducing in the capsule considerable constructional complications, and not overcoming the problem of the residual beverage dripping when the exhausted capsule is removed.

[0006] In particular, WO 2015/124526 unsatisfactorily addresses the dripping problem by providing a tubular appendage closed at the top end by a wall formed in one piece with the lateral wall of the tubular appendage and provided with an orifice suitably sized to limit the dripping. In particular, the fact that the orifice is formed in a rigid wall results in the orifice remaining permanently open and, hence, being prone to clogging by solid substance particles, so compromising the beverage delivery.

Object of the invention

[0007] The object of the present invention is to provide an improved capsule of the above-described type capable of overcoming the above-described drawbacks and, at the same time, being easy and inexpensive to manufacture.

[0008] According to the present invention, a capsule for producing a beverage is provided, as claimed in claim 1, and, preferably, in any one of the claims directly or indirectly dependent on claim 1.

Brief Description of the Drawings

[0009] The invention will now be described with reference to the accompanying drawings, which illustrate a non-limiting embodiment thereof, in which:

- Figure 1 shows, in sectional view, a preferred embodiment of the capsule according to the present invention;
- Figure 2 is a perspective view from below of the capsule of Figure 1;
- Figure 3 is a plan view of a detail of Figure 2;
- Figure 4 is an exploded view of the capsule of Figure 1; and
- Figure 5 shows a few embodiments of the membrane shown in Figure 4.

Preferred embodiments of the invention

[0010] In Figure 1, reference numeral 1 indicates, as a whole, a capsule adapted to contain a substance for producing brewing beverages, such as, coffee, tea, cocoa, milk, broth, etc.

[0011] The capsule 1 is adapted to be used in well-known brewing devices (not shown), where the brewing process comprises sealing the capsule in a seat and supplying in the capsule a warm or cold pressurised fluid, usually water, so that the substance in the capsule may percolate under pressure, thereby producing the relevant beverage.

[0012] As shown in Figures 1 and 2, the capsule 1 comprises an outer casing defined by a cup-shaped body 2 having a longitudinal axis 3, and by a cover 4, which consists of a film made of one or more layers of plastic and/or metal material and is seal-welded to an annular flange 5 arranged at the open end of the cup-shaped body 2 and extending from the cup-shaped body 2 towards the outside transversely to the axis 3.

[0013] The cup-shaped body 2 comprises a lateral wall 6, which is coaxial with the axis 3, is provided at a top axial end thereof with said flange 5, and is preferably provided with a plurality of reinforcing sunken portions 7 evenly distributed around the axis 3.

[0014] The cup-shaped body 2 also comprises a bottom wall 8 connected to the lower axial end of the lateral wall 6 and is provided with a tubular appendage 9, which

extends, at least partially, inside the capsule 1 coaxially with the axis 3 and defines, at an axial end thereof facing the outside of the capsule 1, a beverage dispensing nozzle 10.

[0015] In particular, according to a preferred embodiment shown in Figures 1 and 2, the bottom wall 8 comprises a peripheral annular portion 11 generally convex in shape towards the exterior of the capsule 1 and connected to the lateral wall 6 directly or, preferably, by means of a flat annular portion 12 transverse to the axis 3. The bottom wall 8 further comprises a central tubular portion 13, which extends coaxially with the axis 3 from an inner peripheral edge of the annular portion 11 and is connected, at the opposite end, to the tubular appendage 9.

[0016] Preferably, the central portion 13 has a concave frustoconical shape, which is tapered towards the inside of the capsule 1 so as to protrude beyond the rest of the bottom wall 8 inside the capsule 1.

[0017] As shown in Figure 1, the tubular appendage 9 extends through the central portion 13, and has an inner section 14, which prolongs from the bottom wall 8 towards the inside of the capsule 1, and an outer section 15, which prolongs from the bottom wall 8 towards the outside of the capsule 1 and defines, with the inner section 14, a beverage outflow channel 16. In particular, the beverage outflow channel 16 has an intermediate converging portion 17, which is arranged immediately upstream from a cylindrical or diverging end portion 18, defines, together with the end portion 18, the above-mentioned beverage dispensing nozzle 10, and has the function, during use, of conveying towards the centre of the channel 16 the beverage that flows through the tubular appendage 9, so that the beverage exits the end portion 18 in the form of a compact stream.

[0018] As clearly shown in Figure 3, for this purpose, the end portion 18 is also preferably provided with an axial insert 19 integrally connected to the lateral wall of the outer section 15 by means of radial baffles 20 - three in the example shown - configured to split the end portion 18 into respective separate ducts 21, which further improve the guidance of the output flow and prevent the formation of splashes.

[0019] Given the above, it is appropriate that the intermediate converging portion 17 has a length, with respect to the total length of the beverage outflow channel 16, that is sufficient to ensure the above-described flow "compacting" effect. Preferably, its length is at least equal to about 1/3 of the total length of the beverage outflow channel 16.

[0020] On the basis of the manufacturing technique selected to produce the capsule 1, the need to have a sufficiently long converging section is met by means of appropriately selecting the shape and geometry of the capsule 1.

[0021] For instance, according to the preferred embodiment illustrated in the attached figures, the cup-shaped body 2 is obtained by injection moulding of thermoplastic

material for food use, in particular polypropylene (PP) or polybutylene terephthalate (PBT), and therefore the lateral wall 6, the bottom wall 8 and the tubular appendage 9 are formed in one piece.

5 [0022] Moreover, in this case, the intermediate converging portion 17 of the channel 16 is defined by a respective converging portion of the outer section 15, and the inner section 14 of the tubular appendage 9 and the corresponding portion of the beverage outflow channel 16 have a cylindrical shape coaxial with the axis 3.

10 [0023] As shown in Figure 1, the inner section 14 extends inside the capsule 1, preferably up to about 2/3 of the height of the lateral wall 6, and defines, with the lateral wall 6 and the bottom wall 8, an annular volume 22 adapted to contain the substance to be brewed.

15 [0024] The function of the tubular appendage 9 is to make sure that, in use, the pressurised hot or cold water supplied into the capsule 1 through the cover 9, by means of one or more known perforating member, does not reach the exit directly by flowing from the top to the bottom through the substance to be brewed, but, in order to exit the capsule 1, goes back from the bottom to the top and reaches the end of the tubular appendage 9, creating, within the capsule 1, turbulent movements which promote a capillary penetration of the fluid into the substance to be brewed.

20 [0025] In order to further improve the extraction under pressure and control the pre-brewing phase, i.e. the above-described phase in which the substance is permeated by the brewing fluid and the beverage has not yet reached the beverage outflow channel 16, the free end of the tubular appendage 9 is provided with a membrane 23 configured to allow the beverage to flow through the beverage outflow channel 16 only when the pressure inside the capsule 1 reaches a predetermined threshold value.

25 [0026] As shown in Figures 4 and 5, in a preferred embodiment, the membrane 23 is obtained from a film of polymeric material welded to the free edge of the inner end of the tubular appendage 9 and has a plurality of through micro-slots 24, whose size, shape and arrangement may vary as a function of the type of beverage to be dispensed. By way of example, Figure 5 illustrates a few possible embodiments of micro slots 24.

30 [0027] The micro-slots 24 allow or inhibit the outflow of the beverage from the capsule 1 depending on the pressure conditions inside the same. In particular, the flaps of the micro-slots 24 are normally close together and during the wrapping, packaging, storage and transport steps they prevent leakage of soluble powder from the capsule 1. During the use of the capsule 1, the increase in pressure inside the capsule 1 itself following the feeding of the pressurised water causes the separation of the flaps of each of the micro-slots 24 which, by opening, allow the passage of the beverage inside the channel 16. Therefore, the morphology of the micro-slots 24 determines the threshold value of the internal pressure, at which the flaps of the micro slots 24 bend, and

thus contributes to the adjustment of the pressure inside the capsule 1 and of the flow rate of the beverage.

[0028] When, at the end of the dispensing operation, the pressure inside the capsule 1 drops, the flaps of the micro-slots 24 tend to return elastically into their original position, causing at least partial reclosure of the micro-slots 24; in this way, the dripping that can occur when the capsule 1 is removed from the brewing device (not shown), due to the beverage residues remaining inside the capsule 1, is eliminated, or at least limited.

[0029] According to a variant, not shown, the membrane 23 is obtained from a multilayer sheet comprising a thin sheet of metallic material, for example aluminium or other well-known alloys, and a plastic film which is similar to the plastic film with micro slots previously described with reference to the attached figures, and stably connected to the sheet of metallic material. The membrane 23 is welded or glued, on the side of the metal sheet, to the free edge of the tubular appendage 9 so as to seal the capsule 1, while the micro-cut plastic film is facing the inside of the capsule 1. In use, the increase in pressure inside the capsule 1 following the feeding of the pressurised water causes widening of the micro slots and tearing of the metal sheet at the micro slots, with consequent outflow of the beverage through the channel 16.

[0030] The advantages brought about by the present invention are apparent from the above description. In particular, compared to the solution described in WO 2015/124526, the provision of a membrane, which is applied to the end of an open tubular appendage and obtained from a film of polymeric material provided with a plurality of through slots configured to widen under pressure inside the capsule, allows to implement a considerably more effective anti-dripping function. Indeed, the fact that the pre-cuts are made in a relatively flexible membrane causes them to go back to a substantially closed configuration at the end of the dispensing operation and avoids the risk of them being clogged by solid particles of the substance, which compromises the dispensing of the beverage.

Claims

1. A capsule for preparing a beverage, the capsule (1) comprising a cup-shaped body (2), which is adapted to contain a dose of a substance to be brewed, has a longitudinal axis (3), and comprises a lateral wall (6) coaxial with the axis (3), a bottom wall (8), and a tubular appendage (9), which extends from the bottom wall (8) towards the inside of the capsule (1) and defines a beverage outflow channel (16); the capsule (1) is also provided with a cover (4) to close the cup-shaped body (2), and the tubular appendage (9) has a first axial end facing the cover (4) and defining the inlet of the beverage outflow channel (16), and a second axial end defining the outlet of the beverage outflow channel (16); the capsule (1) is **characterised**

in that it further comprises a membrane (23) firmly connected to the first end of the tubular appendage (9) and provided with a plurality of through slots (24) configured to widen when the pressure inside the capsule (1) reaches a predetermined threshold pressure as a consequence of a pressurised fluid being injected into the capsule (1).

2. The capsule according to claim 1, wherein the membrane (23) is obtained from a film of polymeric material and the number, shape and size of the slots (24) are such as to define said predetermined threshold pressure and the flow rate of the beverage delivered from the capsule (1).
3. The capsule according to claim 2, wherein the slots (24) are configured to reclose at least partially when the pressure inside the capsule (1) drops below said predetermined threshold pressure.
4. The capsule according to claim 1, wherein the membrane (23) is obtained from a multilayer sheet comprising a polymeric film provided with said through slots (24), and an unslotted metallic foil firmly welded to the first end of the tubular appendage (9) and configured to tear when the beverage flows through the polymeric film.
5. The capsule according to one of the preceding claims, wherein the beverage outflow channel (16) has a converging portion (17) immediately upstream from outlet of the beverage outflow channel (16).
6. The capsule according to claim 5, wherein the length of the converging portion (17) of the beverage outflow channel (16) is at least equal to 1/3 of the total length of the beverage outflow channel (16).
7. The capsule according to claim 5 or 6, wherein the bottom wall (8) has a central portion (13) coaxial with the axis (3) and sunken towards the inside of the capsule (1); the tubular appendage (9) extends from an inner end of said central portion (13) and comprises a first section (14) prolonging from the central portion (13) towards the inside of the capsule (1), and a second section (15) prolonging from the central portion (13) towards the outside of the capsule (1); the converging portion (17) of the beverage outflow channel (16) is provided in the second section (15).
8. The capsule according to one of the preceding claims, wherein the lateral wall (6), the bottom wall (8), and the tubular appendage (9) are formed in one piece by an injection moulding process.

Patentansprüche

1. Kapsel zum Zubereiten eines Getränks, wobei die Kapsel (1) umfasst: einen becherförmigen Körper (2), der angepasst ist, eine Dosis einer zu brauenden Substanz zu enthalten, eine Längsachse (3) aufweist und eine Seitenwand (6) koaxial zu der Achse (3) umfasst, eine Bodenwand (8) und einen rohrförmigen Ansatz (9), der sich von der Bodenwand (8) zu der Innenseite der Kapsel (1) erstreckt und einen Getränkeauslaufkanal (16) definiert; wobei die Kapsel (1) auch mit einer Abdeckung (4) versehen ist, um den becherförmigen Körper (2) zu verschließen, und der rohrförmige Ansatz (9) ein erstes axiales Ende, das der Abdeckung (4) zugewandt ist und den Einlass des Getränkeauslaufkanals (16) definiert, und ein zweites axiales Ende aufweist, das den Auslass des Getränkeauslaufkanals (16) definiert; wobei die Kapsel (1) **dadurch gekennzeichnet ist, dass** sie ferner eine Membran (23) umfasst, die fest mit dem ersten Ende des rohrförmigen Ansatzes (9) verbunden ist und mit einer Mehrzahl von Durchgangsschlitzten (24) versehen ist, die so konfiguriert sind, dass sie sich erweitern, wenn der Druck in der Kapsel (1) als Folge des Einspritzens eines unter Druck stehenden Fluids in die Kapsel (1) einen vorbestimmten Schwellendruck erreicht.
2. Kapsel nach Anspruch 1, wobei die Membran (23) aus einem Film aus Polymermaterial erhalten wird und die Anzahl, Form und Größe der Schlitzte (24) derart ist, dass sie den vorbestimmten Schwellendruck und die Durchflussrate des aus der Kapsel (1) gelieferten Getränks definieren.
3. Kapsel nach Anspruch 2, wobei die Schlitzte (24) so konfiguriert sind, dass sie sich zumindest teilweise wieder schließen, wenn der Druck in der Kapsel (1) unter den vorbestimmten Schwellendruck fällt.
4. Kapsel nach Anspruch 1, wobei die Membran (23) aus einer mehrschichtigen Folie, die einen Polymerfilm umfasst, der mit den Durchgangsschlitzten (24) versehen ist, und einer ungeschlitzten Metallfolie erhalten wird, die fest an das erste Ende des rohrförmigen Ansatzes (9) geschweißt ist und konfiguriert ist, zu reißen, wenn das Getränk durch den Polymerfilm fließt.
5. Kapsel nach einem der vorhergehenden Ansprüche, wobei der Getränkeauslaufkanal (16) einen konvergierenden Abschnitt (17) unmittelbar stromaufwärts des Auslasses des Getränkeauslaufkanals (16) aufweist.
6. Kapsel nach Anspruch 5, wobei die Länge des konvergierenden Abschnitts (17) des Getränkeauslaufkanals (16) mindestens 1/3 der Gesamtlänge des

Getränkeauslaufkanals (16) beträgt.

7. Kapsel nach Anspruch 5 oder 6, wobei die Bodenwand (8) einen zentralen Abschnitt (13) aufweist, der koaxial zu der Achse (3) ist und zur Innenseite der Kapsel (1) hin versenkt bzw. abgesenkt ist; wobei sich der rohrförmige Ansatz (9) von einem inneren Ende des zentralen Abschnitts (13) erstreckt und einen ersten Bereich (14), der sich von dem zentralen Abschnitt (13) zu der Innenseite der Kapsel (1) erstreckt bzw. verlängert, und einen zweiten Bereich (15) umfasst, der sich von dem zentralen Abschnitt (13) zu der Außenseite der Kapsel (1) erstreckt bzw. verlängert; wobei der konvergierende Abschnitt (17) des Getränkeauslaufkanals (16) in dem zweiten Bereich (15) bereitgestellt ist.
8. Kapsel nach einem der vorhergehenden Ansprüche, wobei die Seitenwand (6), die Bodenwand (8) und der rohrförmige Ansatz (9) durch einen Spritzgussvorgang einstückig ausgebildet werden.

Revendications

1. Capsule pour la préparation d'une boisson, la capsule (1) comprenant un corps en forme de coupelle (2) qui est adapté pour contenir une dose d'une substance à infuser, présente un axe longitudinal (3), et comprend une paroi latérale (6) coaxiale à l'axe (3), une paroi inférieure (8), et un appendice tubulaire (9) qui s'étend depuis la paroi inférieure (8) vers l'intérieur de la capsule (1) et définit un canal de flux de sortie de boisson (16) ; la capsule (1) est aussi dotée d'un couvercle (4) pour fermer le corps en forme de coupelle (2), et l'appendice tubulaire (9) présente une première extrémité axiale tournée vers le couvercle (4) et définissant l'entrée du canal de flux de sortie de boisson (16), et une seconde extrémité axiale définissant la sortie du canal de flux de sortie de boisson (16) ; la capsule (1) est **caractérisée en ce qu'elle** comprend en outre une membrane (23) raccordée fermement à la première extrémité de l'appendice tubulaire (9) et dotée d'une pluralité de fentes débouchantes (24) configurées pour s'élargir lorsque la pression à l'intérieur de la capsule (1) atteint une pression seuil prédéterminée suite à l'injection d'un fluide sous pression dans la capsule (1).
2. Capsule selon la revendication 1, dans laquelle la membrane (23) est obtenue à partir d'un film de matériau polymère et le nombre, la forme et la taille des fentes (24) sont tels qu'ils définissent ladite pression seuil prédéterminée et le débit de la boisson distribuée par la capsule (1).
3. Capsule selon la revendication 2, dans laquelle les fentes (24) sont configurées pour se refermer au

moins partiellement lorsque la pression à l'intérieur de la capsule (1) chute sous ladite pression seuil prédéterminée.

4. Capsule selon la revendication 1, dans laquelle la membrane (23) est obtenue à partir d'une feuille multicouche comprenant un film polymère doté desdites fentes débouchantes (24), et un film métallique sans fente soudé fermement à la première extrémité de l'appendice tubulaire (9) et configuré pour se déchirer lorsque la boisson s'écoule au travers du film polymère. 5
10
5. Capsule selon l'une des revendications précédentes, dans laquelle le canal de flux de sortie de boisson (16) présente une portion convergente (17) immédiatement en amont de la sortie du canal de flux de sortie de boisson (16). 15
6. Capsule selon la revendication 5, dans laquelle la longueur de la portion convergente (17) du canal de flux de sortie de boisson (16) est au moins égale à 1/3 de la longueur totale du canal de flux de sortie de boisson (16). 20
25
7. Capsule selon la revendication 5 ou 6, dans laquelle la paroi inférieure (8) présente une portion centrale (13) coaxiale à l'axe (3) et enfoncée vers l'intérieur de la capsule (1) ; l'appendice tubulaire (9) s'étend depuis une extrémité intérieure de ladite portion centrale (13) et comprend une première section (14) se prolongeant de la portion centrale (13) vers l'intérieur de la capsule (1), et une seconde section (15) se prolongeant de la portion centrale (13) vers l'extérieur de la capsule (1) ; la portion convergente (17) du canal de flux de sortie de boisson (16) est prévue dans la seconde section (15). 30
35
8. Capsule selon l'une des revendications précédentes, dans laquelle la paroi latérale (6), la paroi inférieure (8), et l'appendice tubulaire (9) sont formés en une pièce par un processus de moulage par injection. 40
45
50
55

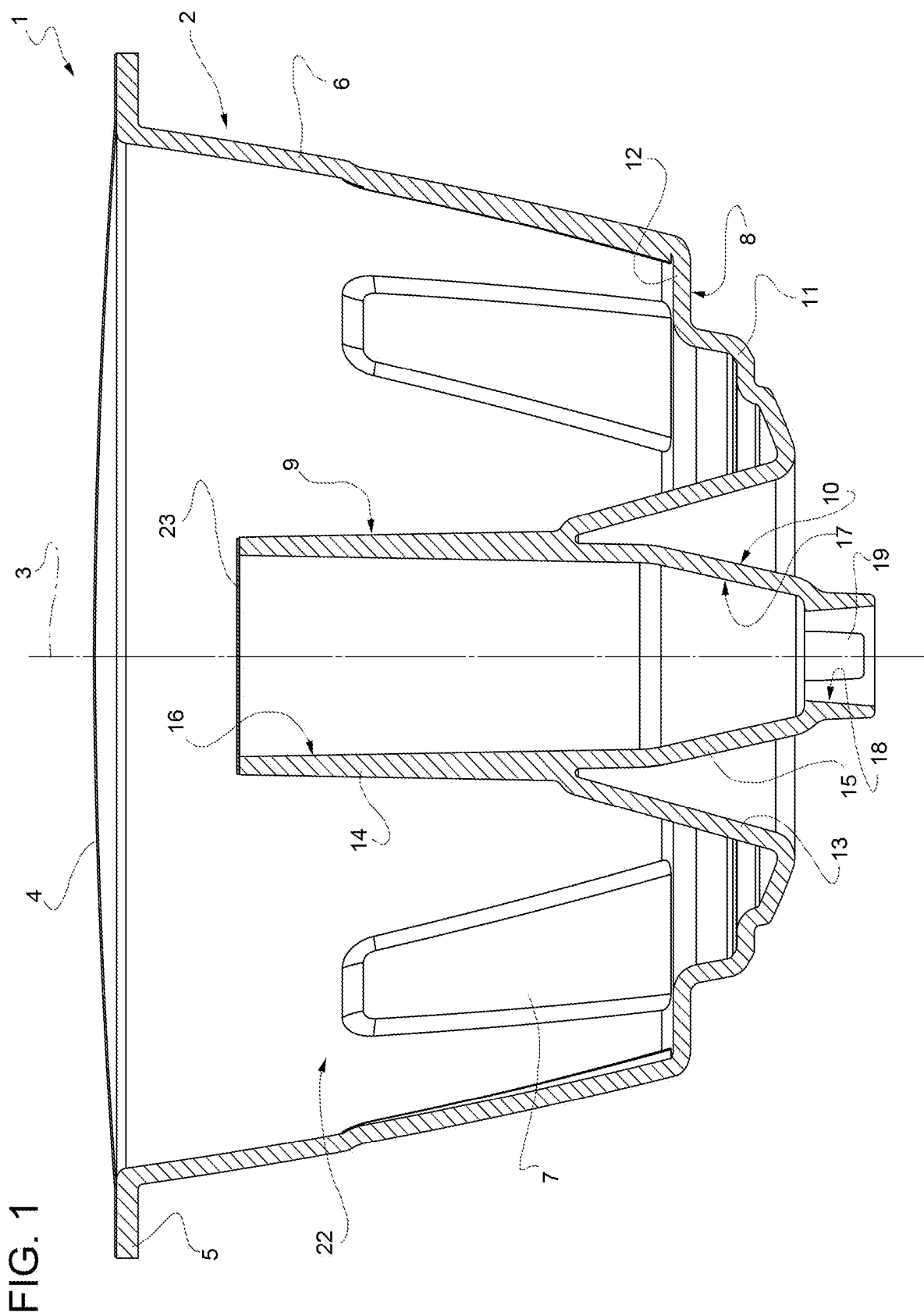

FIG. 1

FIG. 2

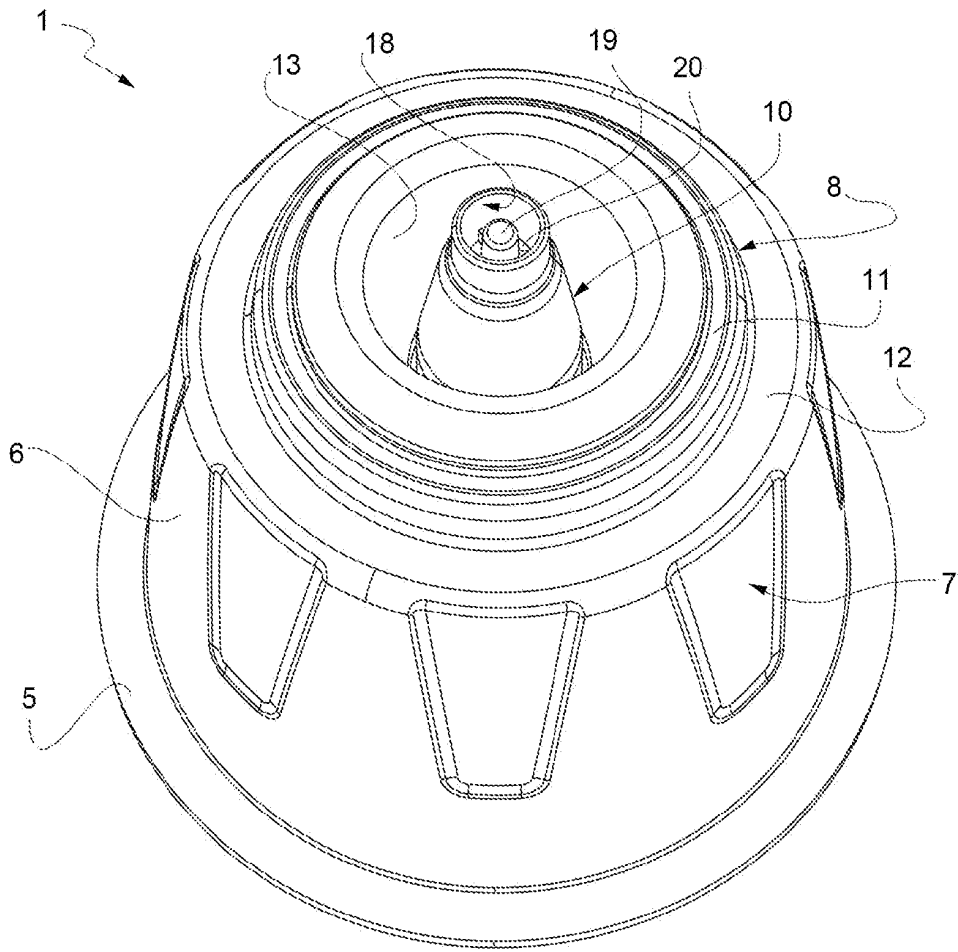
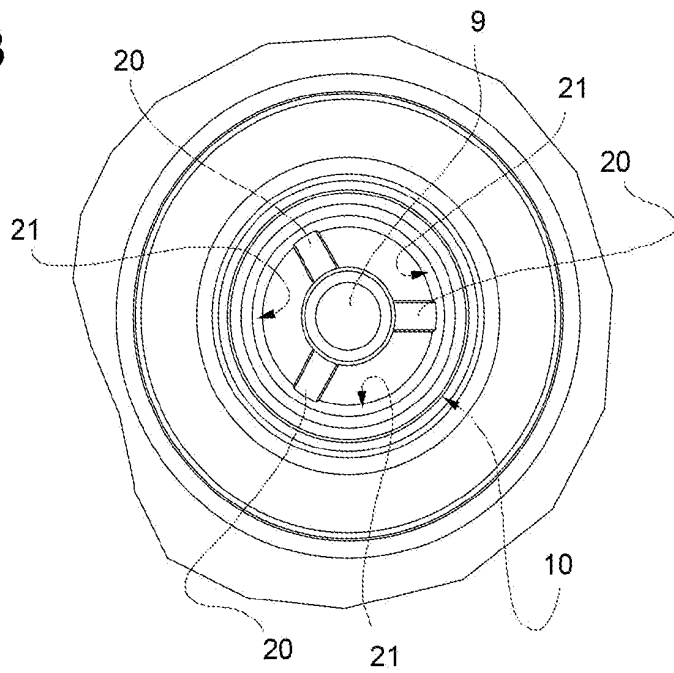

FIG. 3



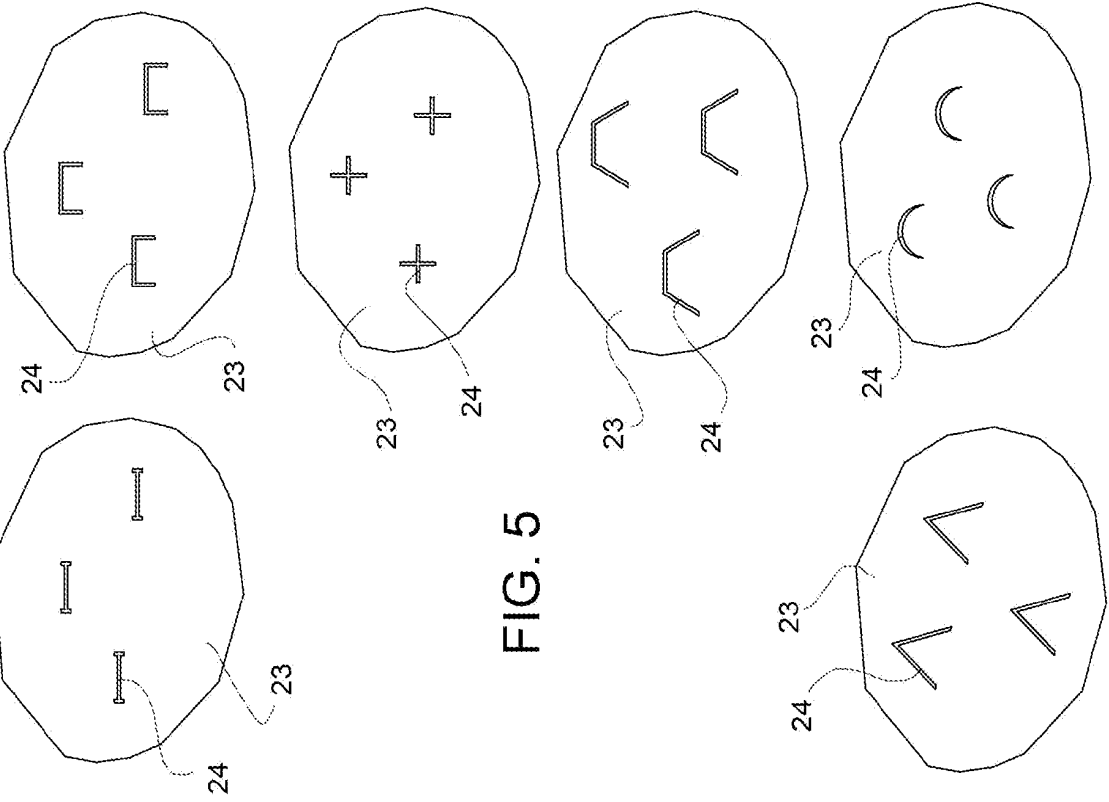

FIG. 5

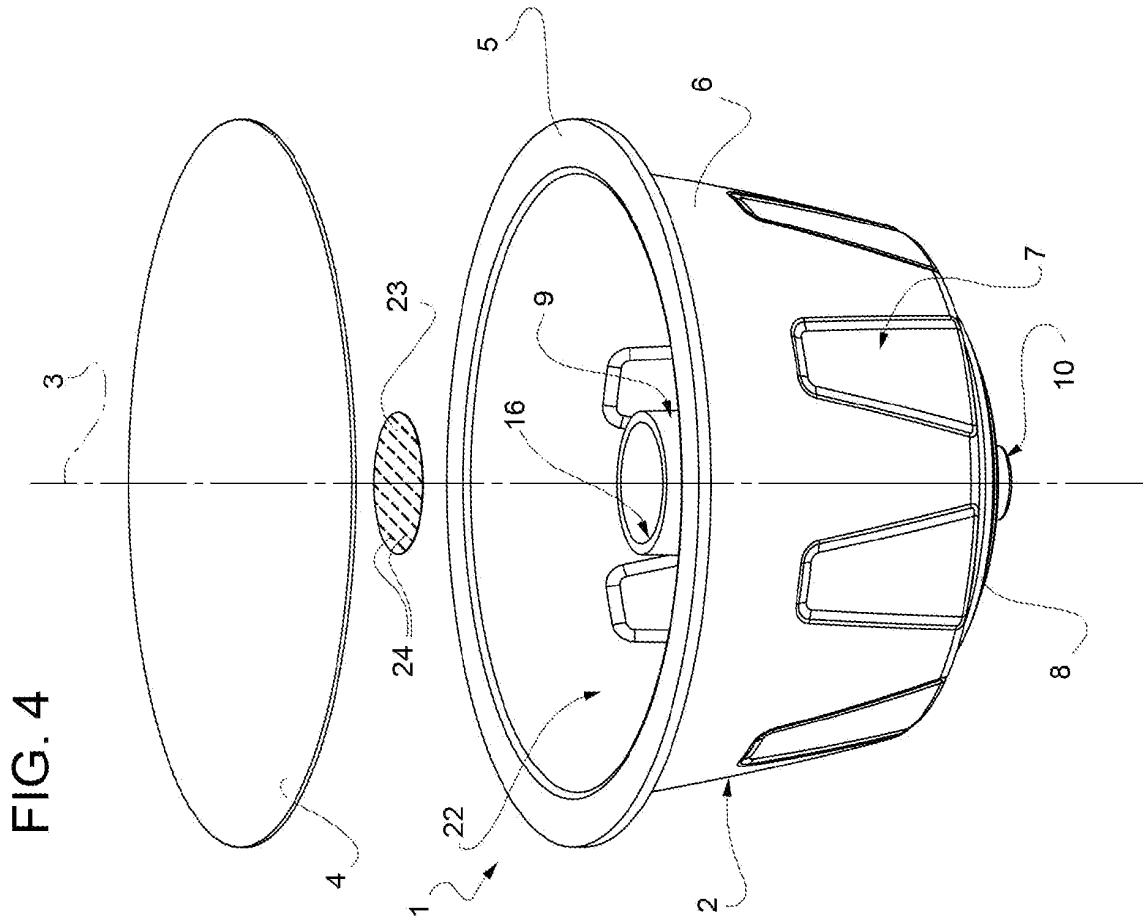

FIG. 4

REFERENCES CITED IN THE DESCRIPTION

This list of references cited by the applicant is for the reader's convenience only. It does not form part of the European patent document. Even though great care has been taken in compiling the references, errors or omissions cannot be excluded and the EPO disclaims all liability in this regard.

Patent documents cited in the description

- EP 0057671 B1 [0002] [0004]
- WO 2015124526 A [0002] [0004] [0006] [0030]