

# HOW TO DO THINGS WITHOUT WORDS

## Multisemiotic visualization in LEGO vs. IKEA building instructions\*

STEFANIA CONSONNI  
UNIVERSITÀ DEGLI STUDI DI BERGAMO

**Abstract** – This study explores LEGO and IKEA building instructions within the broader landscape of multisemiotic qualitative data visualization practices. Building instructions are defined as procedural texts, in which an encoder plans ahead how a practical action is to be undertaken in the real world, and as cognitive protocols, guiding users in the performing of complex tasks by way of rescaling the latter in a sequence of smaller problems, and therefore turning representation into action. The peculiarity of LEGO and IKEA building instructions lays however in the multisemiotic mix through which they perform their referential and instructional functions, which does not comprise verbal language. By way of multisemiotic visualization strategies, LEGO and IKEA building instructions present numerical, topographical, analytical and processual meanings in synoptic, integrated fashion, so as to allow the grasping of articulated data sets on the part of the user. Incorporating Systemic Functional Grammar, classic Social Semiotics and Cognitive Discourse Analysis, this study analyses and contrasts the ideational and interpersonal processes through which LEGO and IKEA building instructions codify empirical phenomena and procedures in such a way as to get unspecialized users to obtain a complete and concrete object from a box of scattered pieces. Attention is finally given to the overarching cultural and epistemological tendency that may be detected behind the fast-growing diffusion of visualization in today’s information dissemination practices, i.e. the spatialization of temporal processes.

**Keywords:** qualitative data visualization; multisemioticity; Cognitive Discourse Analysis; procedural discourse; spatialization of temporal processes.

\* This study is part of a national research project on “Knowledge dissemination across media in English: Continuity and change in discourse strategies, ideologies, and epistemologies”, financed by the Italian Ministry of University and Research (PRIN 2015TJ8ZAS).



## 1. Introduction: building instructions as referential and instructional protocols

This is an exploratory investigation of LEGO and IKEA building instructions as a case study in multisemiotic data visualization (Benking 2005; Vertesi 2014). Based on the coaxing of empirical phenomena into visual patterns and schematizations (such as, for instance, graphs, maps, charts, or scripto-visual products), data visualization can be quantitative (as with graphs and charts; Tufte 1997, 2001) or qualitative (as with conceptual maps or infographics; Coopmans 2014). Enabling a synoptic and integrated presentation of numerical, topographical, analytical and/or processual knowledge in terms of spatial patterns, relationships, networks and hierarchies, qualitative visualization plays a crucial role in today's information dissemination processes, as is testified by the diffusion of new products and genres, such as digital infographics, in both general and specialised discourse (Friendly 2009).

This study considers the multisemiotic strategies deployed by LEGO and IKEA building instructions on the ideational and interpersonal level (Halliday 2002, 2004), with a view to exploring the procedural and cognitive features of visualization strategies in lay, asymmetric contexts such as the entertainment and home environment industry. In particular, the study analyses their referential and instructional functions, with a focus derived from Systemic Functional Grammar (SFG; Halliday 2002, 2004), in combination with Social Semiotics (Kress, van Leeuwen 1996; van Leeuwen 2005) and Cognitive Discourse Analysis (McKay 1999; Taylor, Tenbrink 2013; Tenbrink, Taylor 2015).

Both LEGO and IKEA sell their products with step-by-step illustrated instructions, guiding users on a conceptual path towards the practical process of building an object, be it for recreational ones (as with brick building), or technical reasons (as in the case of self-assembly furniture). Customers buy a box of pieces that must be assembled following a precise procedure until the object is ready for use. As a text type, building instructions are therefore procedural protocols in which an encoder shows users how to do something, thus planning ahead how an action is to be undertaken in the real world (Pillegaard, Frandsen 1996; Werlich 1976). But they also encode a cognitive process: they display “a given declarative representation” and transform it into action (Tenbrink, Taylor 2015, p. 3). The process through which their cognitive architecture guides users in carrying out complex tasks has been investigated by problem solving studies (McKay 1999; Taylor, Tenbrink 2013). In particular, it has been shown that they reduce the complexity of a problem by way of progressively rescaling and retargeting it into an ordered sequence of smaller problems, each of which is therefore reconceptualized

and simplified. Building instructions, in other words, offer “a breakdown of the original problem into separate solution steps [...] delineating a predetermined solution path” (Tenbrink, Taylor 2015, p. 3).

The pragmatics of building instructions may hence be placed along a continuum between the referential and the instructional function (Gotti 2003; Pérez-Llantada 2020). On the one hand, they have an informative mission in practical contexts, i.e., the transferring of procedural meanings that have to be orderly, complete and comprehensible in order for the user to grasp and reproduce the progressive configuration of the pieces to be put together. A typically reader-based and writer-responsible genre (Schnurr 2013), building instructions instantiate an interplay between an informative demand on the part of the user (‘How do I get from a box of pieces to a complete and concrete object?’) and a corresponding informative offer. On the other hand, they are in fact meant for lay audiences, expected not to have any specific expertise about given contexts. LEGO products, for instance, would hardly expect their embedded end-users to be conversant with engineering, as much as IKEA customers are expected not to be carpentry professionals. To overcome this knowledge gap, building instructions textualize meanings in a clear, schematic and concise way (by way of bullet points, numbering, lettering, etc.), in order for users to understand and perform certain actions and achieve certain results.

A widespread strategy in this respect is the use of multisemiotic resources typical of data visualization, such as graphics (arrows, lines, signs, etc.) and visuals (pictures, sketches, etc.), which, combined with verbal language – as research in multiliteracy and resemiotization processes has shown (see for instance Iedema 2003; O’ Halloran 2004; O’ Halloran, Kay, Tan, Wignell 2016; Rowley-Jolivet 2004) – integrate and facilitate the transmission of meanings. Moreover, if these can be transferred through purely graphic and/or figurative language, instructional texts may avoid resorting to verbal language. This is precisely the case with LEGO and IKEA building instructions, in which there are no words, design being – in itself – information (see Neuenschwander 1993). For this reason, LEGO and IKEA building instructions may be defined as multisemiotic cognitive protocols disregarding the use of verbal language.

In particular, the numerical mode (i.e. mathematical symbols, formulae or tables) provides conventionalised visibility to empirical data, in the form of analysable quantities and comparable proportions (Bertin 2011; O’ Halloran 2008; Rowley-Jolivet 2002). In terms of the cooperative maxims that rule referential communication, numbers anchor representation to the principle of Quantity (Grice 1975, p. 45). The figurative mode, due to its high degree of iconicity (a multifaceted, synchronous referential load, pivoting on the selection of criterial aspects of reality, and calling for disambiguation on

the part of the viewer), instantaneously singles out and objectifies complex contents – i.e. spatial and functional relationships – which would take time to interpret and decode if articulated in verbal language (Arnheim 1969; Diana, Reder 2004; Rowley-Jolivet 2002, 2004). This guarantees that the maxim of Relation (or relevance of information provided; Grice 1975, p. 46) is respected. Graphical language, on account of its monosemic, eidetic and stylised character, encodes phenomena in synoptic fashion, disambiguating and synthesizing them in terms of logical, hierarchical and systemic relations (Bertin 2011; Tufte 1997, 2001). In objectifying the adherence of figurative and numerical representation to the segment of reality they are meant to codify, the overarching language of graphics ensures both Quality (accuracy) and Manner (perspicuity) of information (Grice 1975, p. 46).

In LEGO and IKEA building instructions, mathematical symbols obviously specify how many pieces have to be put together; figurative signs clarify the functional and mechanical connections among components; and graphic elements outline the proper sequence of manual movements to be performed in order to achieve the expected result. The resulting simultaneous articulation of computational, relational and procedural meanings allows for a facilitated and accelerated encoding (and grasping) of data and processes. The latter can thus be conveyed even outside the temporality and sequentiality of the scriptural medium, which is by tradition associated with the representation of time-based referents (Mitchell 1980). As opposed to more traditional data visualization genres such as scientific infographics, which pivot on visual-cum-verbal hybridity, LEGO and IKEA's multisemiotic style leaves the use of verbal language aside. The synoptic and systematic visual processing of factual or conceptual knowledge (Diana, Reder 2004, p. 200) seems to override the traditional verbal component of multiliteracy products and genres. LEGO and IKEA building instructions pivot on a principle of pure “visuospatial thinking” (Taylor, Tenbrink 2013, p. 189). Their instructional format is meant to interact with the audience's “imagery cognitive style” (Bergen, Lindsay, Matlock, Narayanan 2007, p. 734), that is, their growing inclination – while thinking and acting – to understand and process information by means of mental pictures, instead of verbal constructs.

As mentioned above, the three-legged multisemiotic style of LEGO and IKEA building instructions is designed to perform important referential and instructional functions that work – in the SFG framework – on the ideational and interpersonal level. At the ideational level, dealing with how segments of an experiential world are represented by signs (Halliday 2004, p. 29), building instructions carry out their referential task: they use numbers, pictures and graphics in order to show users *what it is* they are building. At the interpersonal level, accounting for social and communicative processes

performed by language (Halliday 2004, p. 29), building instructions accomplish their instructional task, especially by way of directions and caveats (Jary, Kissine 2014; Van Olmen, Heinold 2017). That is to say, they use numbers, pictures and graphics to instruct users as to *how to proceed* in building what they set out to build.

In the light of the above, this study will investigate the genre of building instructions across different linguistic strata (ideational and interpersonal), semiotic modes (numerical, graphical, figurative) and pragmatic functions (referential and instructional). In particular, the following research questions will be addressed: How differently does the multisemioticity of LEGO and IKEA building instructions encode meanings? How do numbers, pictures and graphics replace words in showing users what object they are building (referential function) and in guiding them (instructional function) to assemble the pieces until the object is complete?

In order to address such questions, this study will analyse and compare how LEGO and IKEA building instructions codify and transfer one common referent, i.e. How does one assemble a kitchen cabinet?

## 2. Materials

A qualitative analysis will be carried out, in order to contrast LEGO and IKEA multisemiotic strategies in visualising a common referent, i.e. a kitchen cabinet. In order to do so, two sets of instructions for building the same type of object have been downloaded from the Web in PDF format (see Fig. 1 and Fig. 2).<sup>1</sup> The specificity of their multisemiotic style will be defined in the next two Sections.

### 2.1. LEGO multisemioticity

The LEGO kitchen cabinet comes from a larger set of bricks for building the pseudo-domestic environment of a surfer camper van, in which there is a mini stove-and-oven kitchen module (see Fig. 1).

On neutral background, LEGO building instructions (see Fig. 2) combine the numerical, figurative and graphical modes. They unfold through numbered boxes, each of which displays one step in the assembly procedure. Typological and numerical information (i.e. which pieces to put together, and how many of them) is typically given at the top of the box, usually inside a

<sup>1</sup> Downloaded from <https://www.lego.com/en-us/service/buildinginstructions/search#?text=31079%2520Sunshine%2520Surfer%2520Van%2520LEGO%2520Creator> and [https://www.ikea.com/gb/en/assembly\\_instructions/metod-base-cabinet-for-built-in-oven-sink\\_AA-2119848-1\\_pub.pdf](https://www.ikea.com/gb/en/assembly_instructions/metod-base-cabinet-for-built-in-oven-sink_AA-2119848-1_pub.pdf)

smaller box in a different shade of the same colour (see Fig. 2), while graphical devices (typically arrows, which have the transactional equivalence of ‘clicks’) connect it to the picture of the object being built, and show where they fit.



Figure 1  
LEGO Surfer Camper Van building instructions (cover page).

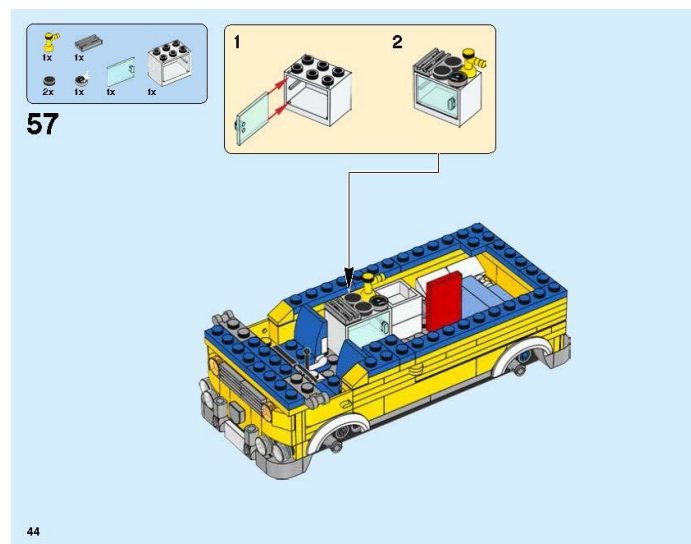

Figure 2  
LEGO building instructions (detail).

Items are illustrated in photorealistic high definition and in frontal isometric perspective, which emphasises the object’s functional and dynamic construction (Kress, Van Leeuwen 1996, p. 85), whereby arrows or other types of vectors are features of directionality signalling the occurring of

particular processes. If the action represented in the box consists of more than one step, it is split up in further sequencing, indicated with the numbers 1, 2, 3, etc. (This additional information comes in smaller boxes in a different colour, which work as magnifying glasses revealing close-up details of the procedure, reconceptualising complex instructional steps by adding supplementary perceptual information, i.e. boosted vision). Graphical elements, such as icons, finally work as visual directives throughout, providing dos and don'ts (Jary, Kissine 2014) – as in the case of tick *vs.* X marks (see Fig. 3), disambiguating right *vs.* wrong, or the double curved arrow signalling ‘turn model around’ (see Fig. 4).

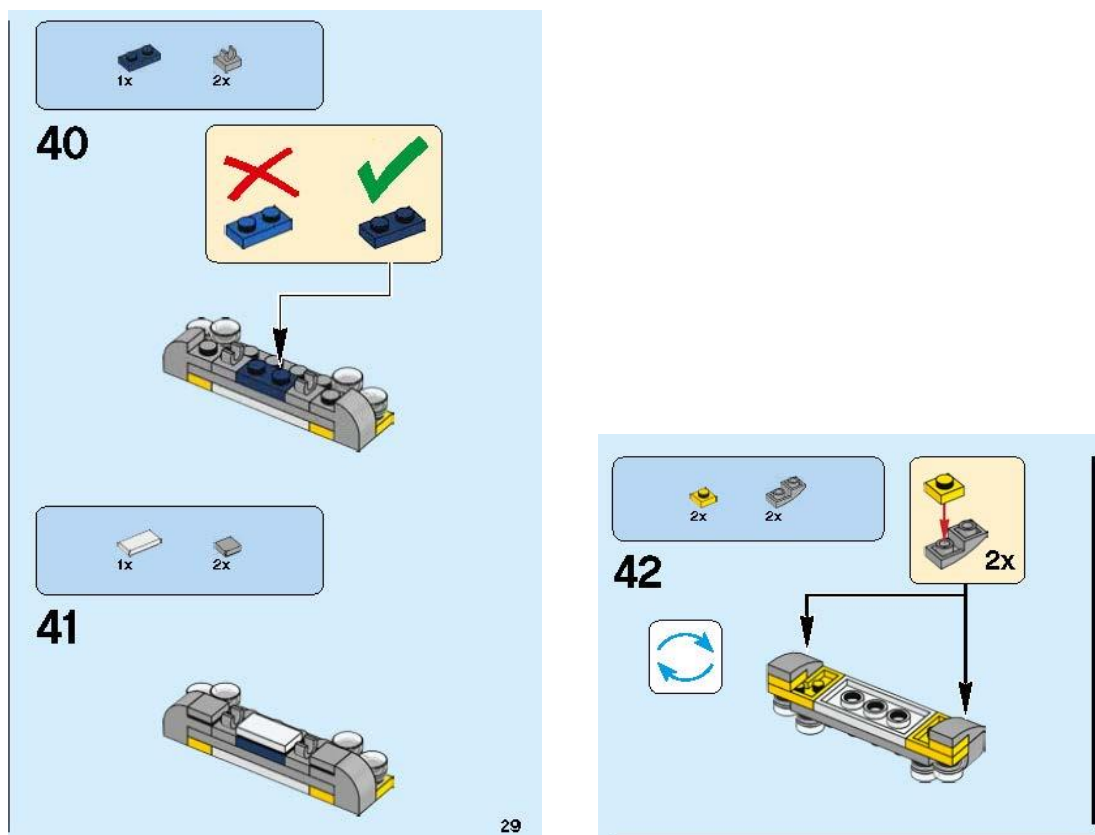

Figure 3 and Figure 4  
LEGO building instructions (detail).

## 2.1. IKEA multisemioticity

The IKEA cabinet, suited for built-in stove-and-oven appliances (40x40x60 cm), belongs to the METOD modular system series (see Fig. 5).



# METOD

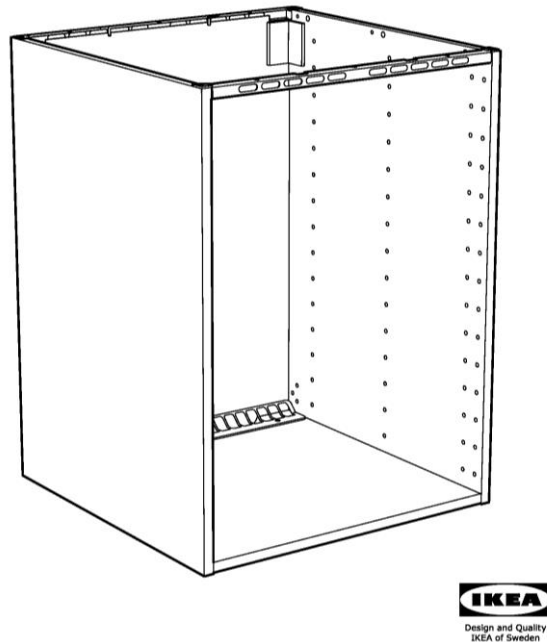

Figure 5  
IKEA Metod Series building instructions (cover page).

IKEA building instructions also revolve around a mix of numerical, figurative and graphical signs. On a white background and in monochrome, they also unfold through numbered boxes. They present typological and numerical information, typically condensing it at the beginning of the document, in the fashion of a preliminary ‘What’s inside the box’ section (see Fig. 6). They also feature graphical language: lines (not arrows) conjoining pieces that fit together; manicules (or pointing indexes) specifying the spot where pieces fit in the model; thought balloons, expressing possible hesitations on the part of the customer; speech balloons, working as magnifying glasses for close-up procedural details; and icons, such as the curved arrow signalling ‘turn object around’ and the X for ‘don’t do this’ in Fig. 6 and Fig. 7.

With respect to LEGO, IKEA instructions make a more extensive use of figurative language, providing drawings in either technological (see Fig. 7) or naturalistic fashion (see Fig. 8), or, as can be seen in Fig. 6, in a cartoonlike style that is reminiscent of Osvaldo Cavandoli’s celebrated 1970s *La linea* (see Pozzo 1995).

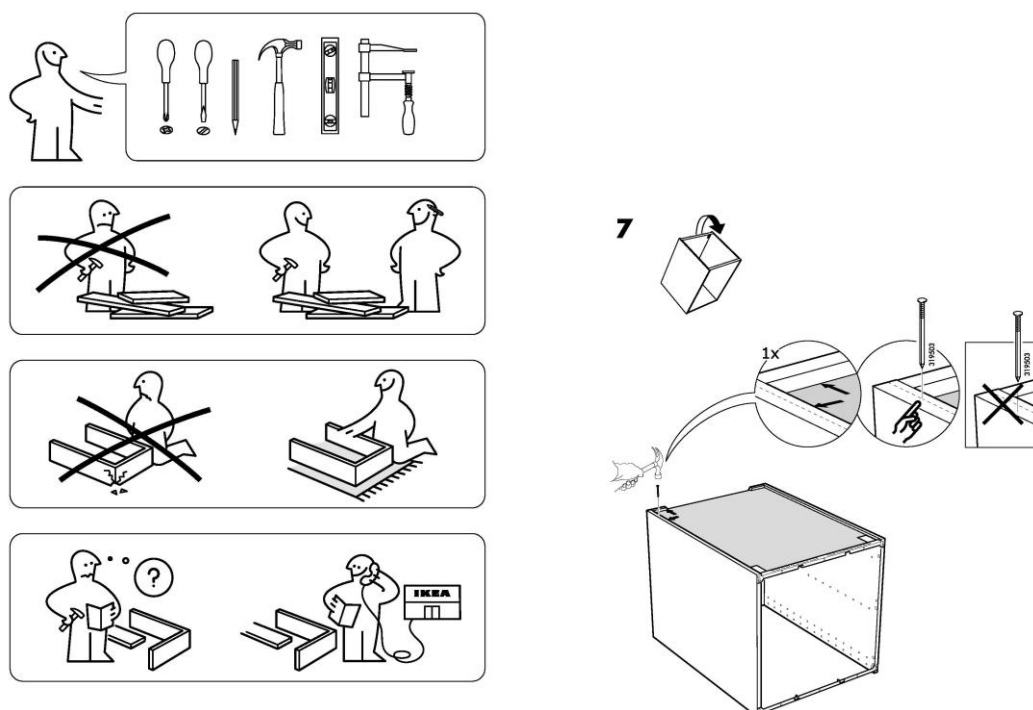

Figure 6 and Fig. 7  
IKEA building instructions (detail).

While technological visuals are used to represent the tools needed when assembling the object (screwdrivers, hammer, bubble level, clamp, a rug for preventing breakages, etc.), naturalistic and cartoonlike visuals alike are used to depict the human world, that is, actors and actions involved in the process – like hammering, or two people turning over a piece of furniture (as shown in Fig. 8).

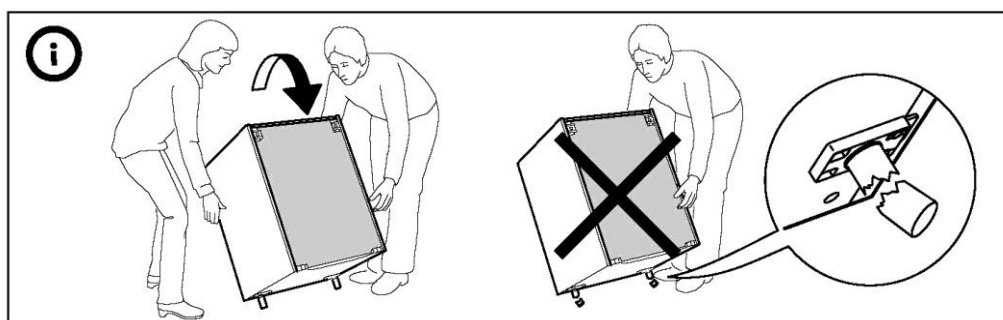

Figure 8  
IKEA building instructions (detail).

### 3. Method

In order to analyse the different types of processes enacted by the multisemiotic mix of LEGO and IKEA language, as well as to highlight the pragmatic functions it performs, and to investigate the broader cognitive affordances of building instructions as visuospatial semantic machineries, this study will incorporate SFG metafunctions (Halliday 2002, 2004), classic Social Semiotics (Kress, Van Leeuwen 1996; LeVine, Scollon 2004; O'Halloran 2004; O'Halloran, E, Podlasov, Tan 2013; O'Halloran, Tan, E 2017; O'Halloran, Tan, Wignell 2016; Van Leeuwen 2005), and Cognitive Discourse Analysis (Taylor, Tenbrink 2013; Tenbrink, Taylor 2015).

### 4. Results

LEGO and IKEA building instructions do perform a referential function (i.e. visualising the finalised, concrete object that is to be assembled) and an instructional function (i.e. providing guidance throughout the assembly process). Both these functions are instantiated by two kinds of representative processes (Halliday 2002, 2004; Kress, Van Leeuwen 1996) that can be identified as the result of their multisemiotic synergy, i.e. narrative and relational processes.

#### 4.1. Narrative processes

##### 4.1.1. Transactional processes in LEGO building instructions

In LEGO instructions (see Fig. 3), narrative processes are always signalled by arrows, that is, graphic vectors marking directionality: Represented Participants (i.e. people and things, concrete or abstract, about which the communication is produced) are depicted as “doing something to or for each other” (Kress, Van Leeuwen 1996, p. 56). Such narrative patterning has the purpose of presenting the unfolding of events and actions, “processes of change” and “transitory spatial arrangements” (Kress, Van Leeuwen 1996, p. 56). In functional semiotic terms, the representation of the LEGO mini-kitchen being assembled in Fig. 2 presents a unidirectional transactional process, i.e. two structural roles (or Participants) unilaterally connected by a transitive action. In particular, the figure shows a number of Actors (the Participants instigating the vector: the bricks presented in numerical formation at the top of the box), one Goal (the Participant at which the vector points: the kitchen cabinet being assembled in the main frame of the box), and a Transaction (the vector itself, signalling something done by an Actor to, or with, a Goal – in this case, bricks building a kitchen cabinet).

If these meanings were to be codified using scriptural signs, this configuration would call for the linguistic expression of action inside a transitive clause (that is, a unidirectional transactional process) by means of syntactic configurations of noun groups and verbal groups. In a visual artefact, this is rendered immediately discernible and expressible by vector-based relations between Participants. The resemiotization of a unidirectional transactional process in linguistic terms (Iedema 2003; O’ Halloran, E, Podlasov, Tan 2013) would call for the use of a transitive verb and a “two-participant material process” (Halliday 2002, p. 103), whereby Actors and Goal (the new bricks, and the developing object) would work as Subject and Object in lieu of noun phrases, and the arrows would function like verbs (the verb *build*). The whole structure would thus form a clause reading like: “LEGO bricks build a kitchen cabinet”.

#### 4.1.2. *Reactional, verbal, mental processes in IKEA building instructions*

In IKEA instructions (see Fig. 6 and Fig. 7), on the contrary, no vectors may be found. A number of lines do conjoin the various pieces to be assembled, but these are not arrows. As a consequence, no transactional processes are depicted, for lines “without an indicator of directionality” do not signal a narrative process, but a relational one (see Section 5.2. below). Three other types of narrative processes are instead to be found in IKEA manuals, which can be labelled as reactional, verbal and mental representations.

Reactional processes involve some represented Participant’s gaze, whereby an eyeline is directed from one Reacter to a Phenomenon. In IKEA building instructions, this typically occurs at the beginning of the assembly procedure, for all IKEA manuals start with the same recommendation section (see Fig. 6), where the aforementioned cartoonlike character, standing on the right hand side of the picture – probably a benevolent caricature of the customer himself – smiles (from top to bottom) at appropriate working tools, at another human figure who is helping him (four hands being better than two), and at the product safely placed on a rug. To the left of the same illustration, the same character unhappily looks at scattered pieces on the floor (for no one is helping him out), at the broken product (due to lack of protective cushioning), and at a confusing step in the assembly process. Visual structures like the ones in Fig. 8 are moreover used to convey dos and don’ts, which is why they also (interpersonally) work as directive strategies (Van Olmen, Heinold 2017).

Speech and mental processes are signalled by the slanting projection of thought and dialogue balloons, connecting representations of speakers and thinkers to the ideational contents of their speech or thought (Kress, Van Leeuwen 1996, p. 67). In functional semiotic terms, these are called

projective structures (Halliday 2002, p. 227), for they display a Phenomenon (the content of the balloon) being mediated by a Reactor who acts as, respectively, Speaker or Senser. Speech balloons are consistently used in IKEA instructions (see Fig. 7 and Fig. 8) to frame and highlight specific sequences of the procedure that are liable to confusion or ambiguity (see the magnifying glass effect shown in Fig. 7, also a feature of LEGO instructions; or the numerical labels, set vertically next to the depicted object in the same figure, indicating production codes in case individual items needed to be replaced). In such cases, the Speaker does not have a human shape; it is the assembled piece of furniture that, to some extent, is shown to ‘speak for itself’. Thought balloons are usually to be found in preliminary sections (see Fig. 6), at the bottom left of the page, where the puzzled user projects his inner mental process in the form of a question mark, pointing to an obvious gap in his knowledge system, soon to be filled by the picture on the right hand side of the frame (where he phones IKEA’s customer service).

If, again, mental projective processes were to be transcoded using verbal language, verbs of perception (*see, hear*) would probably be used, along with verbs of affection (*like, fear*) and verbs signalling processes of cognition, like *know, think* or *believe*, in which there are a Senser (who does the seeing, knowing etc.) and a Phenomenon (being seen, known, etc). Phenomena may also be represented by whole clauses, as in the instance in Fig. 6, where the illustrated mental process sounds like “He does not know”, and the rest of the representation may be complemented by a clause such as “what to do with all this”. Likewise, in the case of speech processes, a linguistic translation would be based on a verb of quotation (*say, claim*), a Sayer – even a non-animate one, such as in this case the assembled piece of furniture –, and a Phenomenon, which may also take the form of a whole clause, both in the form of reported speech (as in “The kitchen cabinet says [that] the screw goes here”) or direct/quoted speech (as in “The kitchen cabinet says: ‘The screw goes here’”).

## 4.2. Relational processes

Relational representations are conceptual structures conveying the equivalent of clauses where “the process is a form of relation between two roles” (Halliday 2002, p. 211). The two roles in question are a Carrier and its Possessive Attributes, for these structures reveal something about “the way participants fit together to make up a larger whole” (Kress, Van Leeuwen 1996, p. 49). Their purpose is to represent referents in terms of class, structure and meaning – depending on their classificatory, analytical or symbolic nature –, thus typologically pointing at “their generalized and more or less stable and timeless essence” (Kress, Van Leeuwen 1996, p. 56).

In both LEGO and IKEA building instructions, analytical processes occur very frequently. Given the pragmatic functions of the genre, this is not surprising: Represented Participants are linked in terms of part-whole structures, where the Carrier (the object being built) presents itself as possessing a number of Possessive Attributes (the assembled pieces). These obey criterial representation, that is, they are selected as contextually relevant, while others are left out as non-essential. Attributes, in turn, allow for the scrutiny and identification of the Carrier (Halliday 2004, p. 223).

#### 4.2.1. *Compounded, exhaustive, topographical structures in LEGO building instructions*

In the case of LEGO (Fig. 2), the kitchen cabinet that is represented as the Goal of a transactional process is also the Carrier of Possessive Attributes, i.e. the bricks it is made of: a yellow tap, three black discs reproducing burners, a transparent square reproducing an oven door. The object is thus structured within an analytical, spatial process which makes it identifiable as “a kitchen module”. Should this configuration be transcoded into verbal language, one would most likely use a possessive (attributive) relational clause (Halliday 2002, p. 121), representing something in terms of more or less permanent states or truths, rather than in terms of actions and reactions, and therefore produce a sentence like “This kitchen cabinet (the Carrier) has such and such LEGO bricks in it (possessive relational process)”.

LEGO relational processes can further be defined as compounded, exhaustive, and topographical. Compounded structures are formed by Attributes “welded together, while at the same time retaining their distinct identities” (Kress, Van Leeuwen 1996, p. 100). LEGO bricks are shown as neither completely merging with one another (as would be the case with fused structures, where the whole is shown at the expenses of parts), nor completely disengaged (as in the case of conjoined structures, where all parts are shown at the expenses of the whole). On the one hand, LEGO Attributes have a precise topographical and epistemological function, i.e. making the Carrier recognisable. And this, it may be argued, is part of the reason why building bricks may be considered as a fully-fledged linguistic system, as well as an intellectually rewarding activity. Playing with LEGO amounts to assembling hundreds, perhaps thousands, of small, geometric pieces in such a way as to produce a criterial and – to an extent which may vary – revealing representation of an empirical or creative referent, be it a 1:800 reproduction of the Empire State Building in the “Architecture” system, for instance, or a fan-designed imaginary pop-up *Once Upon a Brick* fairy tale book in the “Ideas” series. On the other hand, LEGO instructions must highlight the mechanics of the building procedure, illustrating which piece goes where, as is also typical of technical drawing, where the whole object and the

component parts need to integrate to some extent, but not so as to completely blur their boundaries.

Should relational processes be transcoded into verbal language, conjoined structures such as the one visualized in Fig. 2 may be compared to a sentence like “The ship is long”, where the attributive process is still made explicit by the copula. On the other hand, compounded structures may read like “the long ship”, where the attributive process itself is attenuated, but the words remain distinct; and fused structures may be similar to a noun such as “the longship”, where the predication is completely erased by the attributes merging until the structure loses its analytical character (see Kress, Van Leeuwen 1996, p. 53).

#### 4.2.2. Conjoined, exhaustive, topographical structures in IKEA building instructions

Conjoined structures are instead to be typically found in IKEA instructions (see Fig. 9). Here, the analytical process still shows the Carrier (the kitchen module) as made up of a number of interrelated Possessive Attributes (wooden boards, screws, etc.), but such Attributes are connected by simple lines lacking directionality, therefore not signalling any narrative processes.

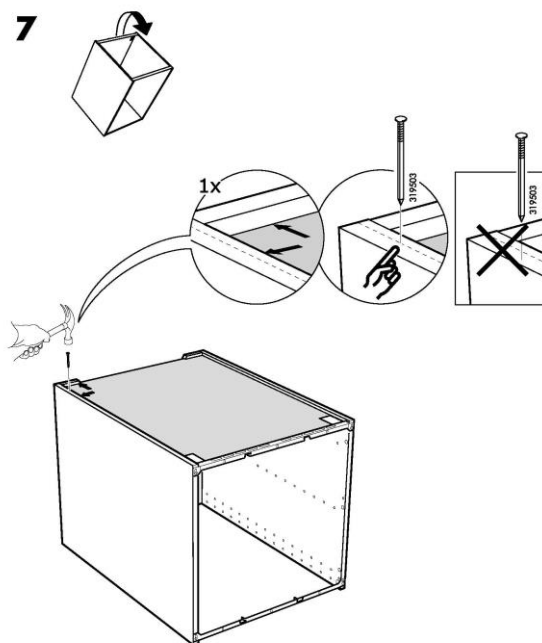

Figure 9  
IKEA conjoined structure.

Such layout separates the components to a certain extent, albeit clearly showing how they fit together. This again serves the purpose of allowing the viewer to scrutinise the mechanics of the procedure, emphasising the

functional welding together of the parts instead of the whole configuration resulting from it. (Which may perhaps be interpreted as a token of IKEA's flat-pack, no-nonsense stance towards interior design.)

IKEA (as well as LEGO) structures are moreover exhaustive, that is, they follow a structural principle of non-selective, holistic assembly, according to which Attributes are joined together in such a way as to form a complex shape that – within the semiotic boundaries and mission of either system – is meant to account for the whole Carrier, not only for some of its parts. This happens in opposition to inclusive analytical structures, where Attributes “do not exhaustively divide up the space of the Carrier”, leaving other parts blank and unanalysed (Kress, Van Leeuwen 1996, p. 98). Both LEGO and IKEA structures are also topographical, since both Carriers read as “accurately representing the physical spatial relations and the relative location of the Possessive Attributes” (Kress, Van Leeuwen 1996, p. 101), in terms of dimensional accuracy (the whole and the parts are drawn to scale) and quantitative exactness and completeness (the quantitative attributes of the parts are fully and correctly represented).

## 5. Discussion: the procedural and cognitive affordances of multisemiotic visualization

The narrative processes described in Section 4.1. showcase some interesting procedural affordances of LEGO and IKEA building instructions. In both cases the assembly process is actually codified – albeit to varying degrees – in dynamic and proactive terms, as a sequence of actions set off and directed by the joint effort of the user's manual abilities and the competence provided by building instructions themselves. And in both cases narrative processes serve a twofold task. They firstly present users with a faithful working representation of the object they are building; secondly, they provide practical directives – especially in the form of dos and don'ts, which are typically conveyed through graphical devices. In the case of LEGO, the same narrative resource is used for both functions: the transactional relationship between Actors and the Goal, graphically conveyed through the directionality of arrows, also foregrounds the architectural and processual significance of ‘making bricks click’ to build a toy version of empirical reality. In the case of IKEA, the directive function is performed by reactional, verbal and mental processes (e.g. eyelines and speech/thought balloons; see Fig. 6 and Fig. 7), while naturalistic or humoristic figuration (see Fig. 8, a realistic portrait of the user, and Fig. 6, benevolently caricaturing him/her) is also used as an interactional reinforcement strategy, in order to create engagement on the part of the customer.



The relational processes analysed in Section 4.2., instead, present the (broader) cognitive pragmatics of LEGO and IKEA building instructions. As is typical of technical visualization practices – such as maps, diagrams, schemes and blueprints –, both LEGO and IKEA represent the assembly process by means of numerical and graphical signs, producing what in fact appears to be an exhaustive and topographical schematization of an empirical referent. Relational processes thus seem to serve both the referential purpose of providing accurate information about the configuration and/or mechanics of the product being built, and the epistemological purpose of boosting the exactness and reliability of building instructions themselves. This may happen in a more dynamic, interactional style – as with LEGO instructions, where compounded structures are used to reveal how strikingly and creatively the predictable geometry of building bricks may be used to imitate (or symbolize) the complexity of real-life referents, such as the kitchen cabinet in question. Or the same effects may be achieved in more static, analytical terms, as is the case with IKEA conjoined structures, the function of which is less visionary (and far more hands-on), i.e. showing users how the component parts fit together until they form a utilizable piece of furniture.

It may furthermore be observed that when codifying the role of the customer in the building procedure, IKEA preferentially resorts to the iconicity and potential polysemy of figurative language (Bernstein 1981; Van Leeuwen 2005), while LEGO tends to convey such meanings mainly via stylised graphic signs. When instead codifying the features of the product, at both referential and instructional level, both IKEA and LEGO resort to graphical and numerical language – that is, to the eidetic, monosemic and analytical visualization that is typical of specialized knowledge, such as for instance engineering or medicine (Coopmans 2014; Rowley-Jolivet 2000, 2002; Vertesi 2014). Multisemioticity may thus be said to cover the whole spectrum of metafunctional strata (ideational, interpersonal), pragmatic purposes (referential, instructional) and epistemological affordances (procedural, cognitive) that are associated with these building instructions as a token of qualitative data visualization.

One may however still wonder: why is the scriptural mode not part of the multisemiotic array? Part of the answer probably lies in the fact that resemiotization – or intersemiotic translation/transmutation (Jakobson 1959; Iedema 2001, 2003) – is a diachronic and unidirectional process, which in Western culture has moved from word to image, progressively shifting the boundaries of discourses and modes from the scriptural to the visual domain, and not the other way around (O' Halloran, Tan, E 2017; O' Halloran, Tan, Wignell 2016). Especially in the context of today's increasing digitalization, resemiotization has involved the technologized re-codification of meanings across ever more propagative semiotics, whereby the linear and irreversible

sequencing of discrete signs, which forms verbal language, has progressively been assisted or accompanied – and in some domains eventually replaced – by the combinative synchronicity of visualization. As mentioned in the Introduction, visual language most efficiently synthesizes complex referents in topological and systemic terms: while verbalization works through the linearity of causal and temporal progression, which readers must necessarily follow in the correct sequence, visualization allows viewers to grasp complex information synoptically and instantaneously. For this reason, in both lay and specialized communication, pictures and graphics have traditionally been employed as “visual glosses” (Hyland 2005, p. 52), i.e. as cognitive facilitators of spatial nature with respect to verbal texts, which they can both illustrate and clarify.

The reverse movement, on the other hand, is most likely to produce not semantic clarity, but opacity – or even ambiguity and confusion. Indeed, the referential and instructional purposes of building instructions seem fully coherent with the cognitive scope and semiotic affordances associable with verbal-to-visual transmutation. Providing guidelines for the undertaking of practical action, displaying protocols that need to be imitated (not interpreted or questioned), the genre of building instructions is not meant to expand or revise knowledge, but to make it digestible and accessible to lay audiences, by breaking down complex ideas into step-by-step procedures that can be visualized and imitated. As a writer-responsible genre, building instructions posit no hermeneutic activity on the part of the reader, a competence that on the contrary is implied in verbal communication, especially when texts of argumentative and persuasive nature – that is, typically writer-based and reader-responsible texts (Schnurr 2013) – are concerned. Furthermore, since the effectiveness of assembly instructions is a direct consequence of the transparency and univocity of the information provided, the risk of redundancy (or loss of perspicuity) inherent in the hypothetical recodification of meanings from visual back into verbal language would not be insignificant.

This may be evidenced by Fig. 10, reproducing a sequence of operating instructions from a 1990s VCR remote control.<sup>2</sup> As anybody who has installed any such appliance will remember, first-generation instructions tended to integrate all four semiotic modes, including the scriptural one, and to indistinctly and repeatedly codify referents and directives across visual and verbal modes (McKay 1999; Tenbrink, Maas 2015). In the case of these remote control functions, a sequence of imperatives (explaining ‘how to watch a tape repeatedly’) is provided in linguistic form in each numbered box

<sup>2</sup> M4E4B VCR User Manual Instruction Book. Downloaded from <https://fccid.io/A7RM4E4B/User-Manual/Instruction-Book-133453>

in the page. But these imperatives are simultaneously resemiotized in iconic terms (see the visual directives provided by pointing indexes and buttons), also in conjunction with graphical and numerical signs (see the lines that connect buttons to the corresponding number in the sequence). The practical mastery of the procedure being explained here may, however, not come as straightforward, since verbal and visual referents overlap and echo each other; directives conveyed in words are duplicated – and made redundant – by graphics and pictures; the numerical information provided in the central section, meant to elucidate the sequence of gestures explained in both words and pictures, is reiterated (1, 1, 2, 3, 3) and made ambiguous. Lay audiences could in fact hardly be expected to successfully imitate such procedure.

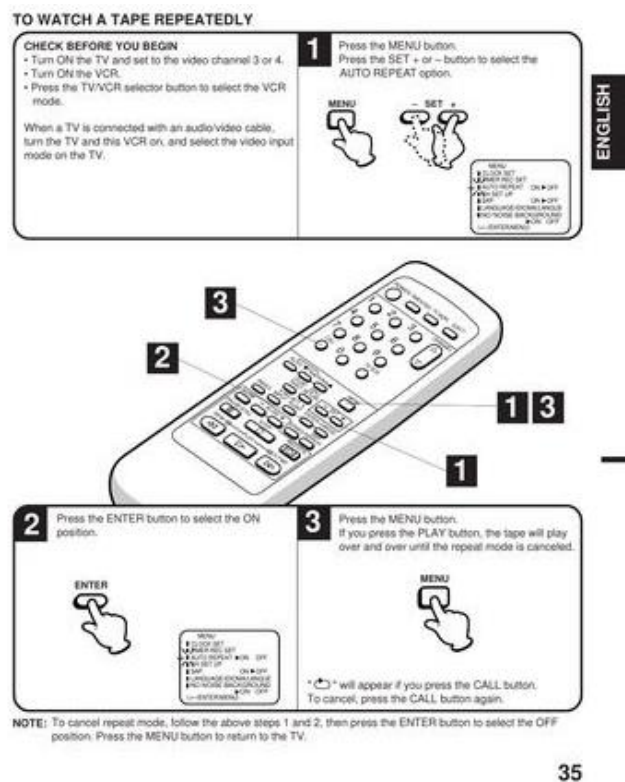

Figure 10  
VCR user manual operating instructions.

This is precisely where today’s fast-growing visual literacy, and the cognitive benefits of qualitative data visualization and “visuospatial thinking” (Taylor, Tenbrink 2013, p. 189) – i.e. the spatialization of processes and structures outside of, and beyond, the temporality inherent in the scriptural medium – may come into play. Multisemiotic visualization may indeed be said to push forward the communicative boundaries of traditional scripto-visual hybridity, particularly in lay contexts, i.e. discourse settings in which disregarding the use

of verbal language is less likely to entail a loss of conceptual or disciplinary complexity.<sup>3</sup>

As the result of multisemiotic visualization, spatialization does significantly occur in LEGO and IKEA building instructions, too, as is evidenced by a closer look at Fig. 2 and Fig. 9 above. Here, narrative and conceptual processes appear to be structurally embedded in one another: the LEGO kitchen cabinet in Fig. 2 works as Relay between a transactional narrative process, in which it acts as Goal, and an analytical relational process, in which it is a Carrier of Attributes. The same happens with the IKEA kitchen cabinet in Fig. 9, working as a Phenomenon within the speech process signalled by the balloon, and as a conjoined structure within an analytical relational process. Both visualizations, that is to say, pivot on the kitchen cabinet being simultaneously presented as a Relay between intrinsically temporal processes (i.e. narrative sequences, be they of transactional, reactional mental and verbal nature) and ultimately spatial structures (i.e. analytical-relational constructs, of exhaustive, topographical, compounded/conjoined nature). It is the radicalized hybridity of temporality and spatiality – better still, of temporality being structurally intertwined with, and subsumed by, spatiality – that indeed construes the kitchen cabinet, along with its referential and instructional implications, as the procedural and cognitive core of these building instructions.

It is thus possible to define LEGO and IKEA visualizations as spatial structures where temporal processes occur, much in the fashion of narrative diagrams (Kress, Van Leeuwen 1996, p. 59). Relational structures in particular, as shown in Section 4.2., function as diagrammatic representations, codifying events and actions taking place over time, such as the assembly process, as visual configurations. Pragmatically speaking, the turning of processes into systems may facilitate the interpretation of instructional meanings, as well as prove a more effective process-oriented learning resource for the engaging of audiences – even junior or unspecialized ones, such as

<sup>3</sup> Words can in fact provide conceptual clarifications and distinctions, for instance in cases of ambiguity or underspecification due to the limits inherent in other semiotic modes. While visualization foregrounds specific segments of reality which are perceived as prominent at the expenses of background elements, the latter may indeed be relevant for a comprehensive overview or analysis of a phenomenon. For this reason, cases of semantic ambiguity may arise and actually be assessed and resolved in linguistic terms. As a symbolic, arbitrary and polysemous system of signification, verbal language can in fact name and define complex ideas, which would be problematic to express through visual language alone. As Denis Diderot's tale *Ceci n'est pas un conte* (1772) and René Magritte's painting *Ceci n'est pas une pipe* (*La trahison des images*, 1929) have clearly shown, a concept like "This is not a pipe" is an instance of those opaque, multi-layered meanings that visual language alone may not be best suited to convey.

those implied by LEGO and IKEA products – in “analysing and transforming information” into concrete action (McKay 1999, p. 324).

## 6. Concluding remarks: towards a spatialization of time processes?

The multisemioticity inherent to qualitative data visualization, as evidenced in the case of LEGO and IKEA building instructions, may emerge as an effective strategy for operatively and cognitively coping with temporal problems. The synoptic and synchronous representation of processes, and above all the spatialization of temporal sequences, which the Discussion in Section 5. above has suggested as the core of LEGO and IKEA diagrammatic representations, seems in this regard to have acquired a function that had traditionally been performed by verbal language, by means of nominalization (or “grammatical metaphor”, Halliday 2004, p. 613), whereby much of the semantic load is conferred to nominal instead of verbal groups.

The illustration in Fig. 9 may on this ground back-translate into a noun phrase like “thumbscrew inserted in dashboard outer edge”. The similarity between verbal nominalization and diagrammatic visualization should by this time come as no surprise, as both phenomena are typical strategies of referential, procedural and expository discourse genres. The use of “a noun instead of a verb to convey concepts relating to actions or processes” (leading in turn to higher nominal density and more lexical conciseness) is motivated by more efficient textual patterning, whereby the thematising of information facilitates the flow of contents in the structure and their grasping by the reader (Gotti 2003, p. 79). As a consequence, information is presented “in its ‘objectified’ form as something to be taken for granted” (Gotti 2003, p. 79), in the same ways as diagrammatic visualization appears to be an increasingly strategic feature for the effectiveness of referential, and in particular, instructional discourse in lay contexts such as the ones under discussion in this paper (Halliday 2002, p. 74; Gotti 2003, p. 179).

In conclusion, although it goes far beyond the scope of this study to gather evidence in this respect, it may be observed that there is an increasing tendency in today’s knowledge dissemination practices and processes – in lay as well as specialized contexts, such as scientific or technological communication (Friendly 2009) – towards the enhanced perceptual experience of data visualization, of which LEGO and IKEA building instructions are one among many possible examples. Within the obvious limits of its object and methodology of analysis, this paper has aimed to suggest that this tendency towards multisemiotic visualization, which ultimately pivots on the spatialization of time processes, may arguably be associated with the progressive emergence of boosted paths for “visual

thinking”, i.e. for ever more persuasive and propagative modes of understanding, processing and transferring information (Pylyshyn 2003). In other words, there seems to be underway a cultural, perhaps more broadly epistemological tendency away from traditional time-based media, towards the spatialized syncretism of figurative and graphical language. Although this tendency distinctly emerges in unspecialized communicative environments – such as the entertainment and home environment industry, as in the case studies that are the object of this paper – it cannot be fully explained in terms of lack of discursive or disciplinary training, or cognitive non-compliance (if not downright laziness) on the part of the audience. The relationship between vision and cognition – which has, for that matter, been there for centuries in the history of speculative thought (Berger 2017) – indeed seems to deserve much more extensive investigation.

**Bionote:** Stefania Consonni is a researcher in English linguistics at the University of Bergamo, Department of Foreign languages, literatures and cultures. She has published books and essays on textual paradigms; narratology; the semiotics of visual and verbal language; specialized communication in a discourse-analytical perspective; the semiotic, pragmatic and epistemological features of traditional and new genres within academic and specialized/scientific discourse. She is a member of CERLIS (Research Centre on Languages for Specific Purposes) and CLAVIER (Corpus and Language Variation in English Research); she is part of the editorial board at JCaDS (Journal of Corpora and Discourse Studies, University of Cardiff), CERLIS series (University of Bergamo), and Ibérica (European Association of Languages for Specific Purposes); she is involved in inter-academic Research Projects, funded by the Italian Ministry of Education, on cultural studies and specialized discourse, and in EU-funded Erasmus+ projects devoted to the teaching of languages for specific purposes.

**Author’s email address:** [stefania.consonni@unibg.it](mailto:stefania.consonni@unibg.it)

## References

- Arnheim R. 1969, *Visual Thinking*, University of California Press, Berkeley and Los Angeles.
- Benking H. 2005, *Using Maps and Models, Supersigns and Superstructures*. <http://benking.de/systems/codata/CODATA-MIST2005.htm> (1.02.2018).
- Bergen B., Lindsay S., Matlock T. and Narayanan S. 2007, *Spatial and Linguistic Aspects of Visual Imagery in Sentence Comprehension*, in "Cognitive Science" 31, pp. 733-764.
- Berger S. 2017, *The Art of Philosophy: Visual Thinking in Europe from the Late Renaissance to the Early Enlightenment*, Princeton University Press, Princeton and Oxford.
- Bernstein B. 1981, *Codes, Modalities and the Process of Cultural Reproduction: A Model*, in "Language and Society" 10, pp. 327-363.
- Bertin J. 2011, *Graphics and Graphic Information Processing*, de Gruyter, Berlin.
- Coopmans C. 2014, *Visual Analytics as Artful Revelation*, in Coopmans C., Vertesi J., Lynch M. and Woolgar S. (eds.), *Representation in Scientific Practice Revisited*, MIT Press, Cambridge, MA, pp. 37-59.
- Diana R.A. and Reder L.M. 2004, *Visual Versus Verbal Metacognition: Are They Really Different?*, in Levin D.T. (ed.), *Thinking and Seeing: Visual Metacognition in Adults and Children*, MIT Press, Cambridge, MA, pp. 198-201.
- Friendly M. 2009, *Milestones in the History of Thematic Cartography, Statistical Graphics, and Data Visualization*. <http://www.datavis.ca/papers/gfkl.pdf> (23.03.2018).
- Gotti M. 2003, *Specialized Discourse: Linguistic Features and Changing Conventions*, Peter Lang, Bern.
- Grice H.P. 1975, *Logic and Conversation*, in Cole P. and Morgan J.J. (eds.), *Syntax and Semantics. Vol. 3: Speech Acts*, Academic Press, New York, pp. 41-58.
- Halliday M.A.K. 2002, *On Grammar*, Continuum, London.
- Halliday M.A.K. 2004, *An Introduction to Functional Grammar: Third Edition*, Hodder Arnold, London.
- Hyland K. 2005, *Metadiscourse*, Continuum, London.
- Iedema R. 2001, *Resemiotization*, in "Semiotica" 137 [1-4], pp. 23-39.
- Iedema R. 2003, *Multimodality, Resemiotization: Extending the Analysis of Discourse as Multisemiotic Practice*, in "Visual Communication" 2 [1], pp. 29-57.
- Jakobson R. 1959, *On Linguistic Aspects of Translation*, in Brower R.A. (ed.), *On Translation*, Harvard University Press, Cambridge, MA, pp. 232-239.
- Jary M. and Kissine M. 2014, *Imperatives*, Cambridge University Press Cambridge.
- Kress G. and van Leeuwen T. 1996, *Reading Images: The Grammar of Visual Design*, Routledge, London.
- LeVine P. and Scollon R. 2004, *Discourse and Technology: Multimodal Discourse Analysis*, Georgetown University Press, Washington.
- McKay E. 1999, *An Investigation of Text-Based Instructional Materials Enhanced with Graphics*, in "Educational Psychology" 19 [3], pp. 323-335.
- Mitchell W.J.T. 1980, *The Language of Images*, University of Chicago Press, Chicago and London.
- Neuenschwander B. 1993, *Letterwork: Creative Letterforms in Graphics Design*, Phaidon, London.

- O'Halloran K.L. (ed.) 2004, *Multimodal Discourse Analysis: Systemic-Functional Perspectives*, Continuum, London.
- O'Halloran K.L. 2008, *Mathematical Discourse: Language, Symbolism and Visual Images*, Continuum, London.
- O'Halloran K.L., E. M.K.L., Podlasov A. and Tan S. 2013, *Multimodal Semiotics: The Interaction of Language with Other Resources*, in "Text & Talk" 33 [4-5], pp. 665-690.
- O'Halloran K.L., Tan S. and E. M.K.L. 2017, *Multimodal Analysis for Critical Thinking*, in "Learning, Media and Technology" 42 [2], pp. 147-170.
- O'Halloran K.L., Tan S. and Wignell P. 2016, *Intersemiotic Translation as Resemiotization: A Multimodal Perspective*, in "Signata" 7, pp. 199-229.
- Pérez-Llantada C. 2020, *Preface*, in Gotti M., Maci S.M. and Sala M. (eds.), *Scholarly Pathways: Knowledge Transfer and Knowledge Exchange in Academia*, Peter Lang, Bern, pp. 5-9.
- Pillegard M. and Frandsen F. 1996, *Text Type*, in Östman J.O. and Verschueren J. (eds.), *Handbook of Pragmatics: Vol. 2*, Benjamins, Amsterdam. <https://doi.org/10.1075/hop.2.tex3>
- Pozzo A. 1995, *Espressioni Lineari: Semiotica dell'Episodio 113 di Osvaldo Cavandoli*, in Bendazzi G., Cecconello M. and Michelone G. (eds.), *Coloriture. Voci, rumori, musiche nel cinema di animazione*, Pendragon, Bologna, pp. 209-215.
- Pylyshyn Z. 2003, *Seeing and Visualizing: It's Not What You Think*. MIT Press, Cambridge, MA.
- Rowley-Jolivet E. 2000, *Image as Text: Aspects of the Shared Visual Language of Scientific Conference Participants*, in "Asp" 27-30, pp. 133-154.
- Rowley-Jolivet E. 2002, *Visual Discourse in Scientific Conference Papers: A Genre-Based Study*, in "English for Specific Purposes" 21 [1], pp. 19-40.
- Rowley-Jolivet E. 2004, *Different Visions, Different Visuals: A Social-Semiotic Analysis of Field-Specific Visual Composition in Scientific Conference Presentations*, in "Visual Communication" 3 [2], pp. 145-175.
- Saint-Martin F. 1987, *Sémiologie du langage visual*, Presses de l'Université de Québec, Québec.
- Schnurr S. 2013, *Exploring Professional Communication: Language in Action*, Routledge, London.
- Taylor H.A. and Tenbrink T. 2013, *The Spatial Thinking of Origami: Evidence from Think-Aloud Protocols*, in "Cognitive Processing" 14, pp. 189-191.
- Tenbrink T. and Taylor H.A. 2015, *Conceptual Transformation and Cognitive Processes in Origami Paper Folding*, in "Journal of Problem Solving" 8. <http://dx.doi.org/10.7771/1932-6246.1154>.
- Tenbrink T. and Maas A. 2015, *Efficiently Connecting Textual and Visual Information in Operating Instructions*, in "IEEE Transactions on Professional Communication" 58 [4], pp. 346-366.
- Tufte E.R. 1997, *Visual Explanations: Images and Quantities, Evidence and Narrative*, Graphics Press, Cheshire.
- Tufte E.R. 2001, *The Visual Display of Quantitative Information*, Graphics Press, Cheshire.
- Van Leeuwen T. 2005, *Introducing Social Semiotics*, Routledge, London.
- Van Olmen D. and Heinold S. 2017, *Imperatives and Directive Strategies*, Benjamins, Amsterdam.
- Vertesi J. 2014, *Drawing As: Distinctions and Disambiguation in Digital Images of Mars*,



in Coopmans C., Vertesi J., Lynch M. and Woolgar S. (eds.), *Representation in Scientific Practice Revisited*, MIT Press, Cambridge, MA, pp. 15-35.  
Werlich E. 1976, *A Text Grammar of English*, Quelle & Meyer, Leipzig.