



Optimum tuning of Tuned Mass Dampers for frame structures under earthquake excitation

Journal:	<i>Structural Control and Health Monitoring</i>
Manuscript ID:	STC-13-0134.R2
Wiley - Manuscript type:	Research Paper
Date Submitted by the Author:	23-Jun-2014
Complete List of Authors:	Salvi, Jonathan; Università di Bergamo, Dipartimento di Ingegneria Rizzi, Egidio; Università di Bergamo, Dipartimento di Ingegneria
Keywords:	Tuned Mass Damper (TMD), Tuning, Minimax optimization, Time integration, Seismic response, Frame structures
Note: The following files were submitted by the author for peer review, but cannot be converted to PDF. You must view these files (e.g. movies) online.	
Salvi_Rizzi-SCHM-sub04.tex	

SCHOLARONE™
Manuscripts

view

Submitted to Structural Control and Health Monitoring: 23 June 2014

Optimum tuning of Tuned Mass Dampers for frame structures under earthquake excitation

Jonathan SALVI, Egidio RIZZI*

Università di Bergamo, Dipartimento di Ingegneria (Dalmine),
viale G. Marconi 5, I-24044 Dalmine (BG), Italy

*Corresponding Author, email: egidio.rizzi@unibg.it

Abstract

Tuned Mass Damper (TMD) devices are one of the oldest vibration control means and are widely used in different engineering contexts. Despite the bulk of literature on various TMD-related issues, the effectiveness of TMDs in reducing the earthquake response of civil engineering structures is still debated. This paper deals with the optimum tuning of the free parameters of a passive TMD applied to sample frame structures subjected to selected seismic excitations. A tuning procedure consisting of a numerical Minimax optimization algorithm is implemented within MATLAB. The so-conceived TMD turns-out optimum with respect to the specific seismic event, hence allowing for optimum reduction in primary seismic response. Both optimization process and seismic analysis are carried-out in the time domain, through direct integration of the equations of motion. The method is tested on benchmark single- and multi-degree-of-freedom shear-type prototype structures from the literature by assuming first the Imperial Valley 1940 seismic input, as a sort of benchmark excitation, and then additional recent strong motion earthquakes. In essence, this paper shows that, in principle, with present reference to frame structures, the optimum tuning of TMD parameters at given seismic input is theoretically possible.

Keywords: Tuned Mass Damper (TMD), Tuning, Minimax optimization, Time integration, Seismic response, Frame structures.

1 Introduction

This paper concerns the numerical optimization of the free parameters of a Tuned Mass Damper device added to frame structural systems subjected to given seismic excitations. Thus, it mainly presents a theoretical concept of TMD tuning at seismic input. The final purpose of the proposed method is, inter alia, the appropriate design of efficient passive TMD devices for seismic engineering applications. An on-going research project on this topic is under development [1–5], whereby basic tuning concepts have been thoroughly reviewed and a numerical optimization approach has been put in place for canonical force input considered in the literature. Initial outcomes on seismic tuning have been presented in [2]; comprehensive results are derived systematically and reported in details here.

Passive TMDs are one of the oldest and most used vibration control devices, usually composed of an additional (or secondary) mass, an elastic spring and a viscous (or hysteretic) damper attached to a primary structure [6]. After the original introduction of the Tuned Mass Damper concept (probably dated-back to the patent of Frahm in 1911), Ormondroyd and Den Hartog [7], Brock [8] and Den Hartog [9] further improved and

1
2
3
4
5
6
7
8
9
10
11
12
13
14
15
16
17
18
19
20
21
22
23
24
25
26
27
28
29
30
31
32
33
34
35
36
37
38
39
40
41
42
43
44
45
46
47
48
49
50
51
52
53
54
55
56
57
58
59
60

codified these studies. This immediately became the fundamental way of TMD tuning, on which almost all subsequent theories have been based. Afterwards, several studies have been dedicated to the optimum TMD tuning, based on models that are either dependent, e.g. [6, 10–25], or independent, e.g. [26–29], of the external actions.

Following Den Hartog's contribution [9], the approach that contemplates a tuning dependent on the external loadings has been widely studied, especially in the case of damped structural systems [10, 17, 22, 30]. In this sense, the presence of inherent structural damping, which appears realistic for actual buildings and structures, appears to not allow for straight-forward analytical tuning [10, 30]. However, Warburton's works [19–22] have already reported progress in connection to Den Hartog's tuning with respect to harmonic and stationary random excitations. Comparison has already revealed at that stage that even for moderately damped structures (viscous damping ratio up to 5%) Den Hartog's tuning formulas guarantee an adequate structural response decrease. In this connection, also monograph [6] should be mentioned. Anyway, the recourse to numerical optimization algorithms for the TMD tuning in the presence of damped main structures may become an useful and effective option [13, 17, 22].

One may observe from the literature that numerical optimization methods based on Minimax algorithms have been probably the most common computational techniques adopted to evaluate the optimum TMD parameters in the case of damped primary structures, when the structural system is subjected to standard ideal loadings, such as harmonic or Gaussian white noise force or base excitation [11, 16, 17, 24]. In the mainstream literature, the seismic input has been usually assumed in post-tuning numerical trials, in order to investigate the effectiveness of a specific tuning theory within the seismic context. Miranda [27] proposed a numerical tuning procedure based on an energy-based model, whose results confirmed those obtained by Sadek et al. [28]; Marano et al. [31] approached the TMD tuning problem by means of a stochastic optimization procedure. Presently, the seismic TMD assessment still appears to be an open research topic, with conflicting opinions, see e.g. [28, 32–34].

Furthermore, a series of recent works considered the given earthquake input as directly embedded within the tuning process. The main differences among these studies concern the adopted optimization algorithm and the modeling of the seismic input. Some significant works, where the seismic analysis has been carried-out in the frequency domain and the earthquake record is modeled through the Kanai-Tajimi formula [35], are that of Hoang et al. [36], where the TMD tuning was carried-out within a numerical optimization based on the Davidon-Fletcher-Powell algorithm, that of Lee et al. [37], where the Golden Section method was used in the optimization process, and that of Leung et al. [38], where the seismic input was modeled as a non-stationary process and TMD tuning was carried-out within a Particle Swarm Optimization algorithm. Moreover, Farshidianfar et al. [39] considered a forty-storey frame building subjected to a given earthquake, with seismic analysis carried-out in the time domain and TMD parameters optimized through an Ant Colony Optimization method [39]. Adam et al. [40, 41] have dealt with an investigation on two different tuning approaches, one based on literature tuning formulas [22, 36] and on the assumption of simulating the earthquake as a stationary white noise excitation, and the other which considers the actual earthquake record in the frequency domain and recovers, as optimum TMD parameters, the median of those obtained for each seismic input; the so-obtained results pointed-out: (a) a negligible difference between the two adopted approaches, for the considered structures and seismic records; (b) a remarkable effectiveness of TMDs in earthquake applications. Bekdas and Nigdeli [42] proposed a tuning in the frequency domain based on a Harmony Search algorithm, assuming a harmonic load in the optimization process, which has been further tested with a seismic loading. Mohebbi

and Joghataie [43] considered an eight-storey frame building subjected to an earthquake modeled as white noise excitation in the time domain, with a TMD tuned by a Distributed Genetic Algorithm (DGA) optimization.

Nevertheless, it appears that the Minimax optimization method has not been directly applied to the systematic analysis of tuning at given seismic input. This paper inserts itself into this specific recent line of research in TMD tuning and innovatively explores the efficiency of the proposed optimization method through numerical tests on several frame buildings, characterized by different structural parameters. The main novelty aspect of the optimum tuning procedure proposed here is the application of a Minimax optimization algorithm on specific cases of frame structures and of seismic events, so that the so-obtained TMD parameters turn-out optimum for each considered case.

The contents of the paper are organized as follows. The proposed tuning procedure is presented and described in detail in Section 2 and Appendix A. In Section 3 the tuning technique is applied to both SDOF and MDOF structural systems (shear-type frames) from the literature [28,29,38], which are subjected to a benchmark seismic input. The procedure is then further validated and confirmed by additional tests with different earthquakes, with results reported in Section 4.

2 Statement of the optimum tuning procedure

2.1 TMD on a SDOF structure

The system composed of a main SDOF structure, equipped with a TMD located on top and subjected to a base ground acceleration $\ddot{x}_g(t)$ is sketched in Fig. 1. The primary structure (S) is characterized by a mass m_s , a constant linear elastic stiffness k_s and a linear viscous damping coefficient c_s . The natural angular frequency ω_s and damping ratio ζ_s of the primary structure are defined as usual, i.e. respectively:

$$\omega_s = \sqrt{\frac{k_s}{m_s}}, \quad \zeta_s = \frac{c_s}{2\sqrt{k_s m_s}}. \quad (1)$$

Figure 1. Structural parameters and absolute (relative to the ground) degrees of freedom of a 2DOF mechanical system composed of a SDOF primary structure (S) equipped with a TMD (T) added on top, subjected to seismic base excitation.

Conversely, the parameters of the TMD device (T) are an added secondary mass m_T , a stiffness k_T of an added elastic spring and a damping TMD coefficient c_T of an added viscous damper. As above, the TMD angular frequency ω_T and damping ratio ζ_T are respectively:

$$\omega_T = \sqrt{\frac{k_T}{m_T}}, \quad \zeta_T = \frac{c_T}{2\sqrt{k_T m_T}}. \quad (2)$$

The main free TMD parameters, useful to achieve the most appropriate tuning, are defined in terms of mass ratio μ , tuning frequency ratio f of the primary structure+TMD system and damping ratio ζ_T itself, as:

$$\mu = \frac{m_T}{m_s}, \quad f = \frac{\omega_T}{\omega_s} = \sqrt{\frac{1}{\mu} \frac{k_T}{k_s}}. \quad (3)$$

The two equations of motion which govern the dynamic behavior of the structural system represented in Fig. 1, subjected to a seismic base acceleration $\ddot{x}_g(t)$, can be classically expressed as follows, in terms of absolute degrees of freedom x_S, x_T ($x_{TS} = x_T - x_S$):

$$\begin{bmatrix} m_S & 0 \\ 0 & m_T \end{bmatrix} \begin{bmatrix} \ddot{x}_S(t) \\ \ddot{x}_T(t) \end{bmatrix} + \begin{bmatrix} c_S + c_T & -c_T \\ -c_T & c_T \end{bmatrix} \begin{bmatrix} \dot{x}_S(t) \\ \dot{x}_T(t) \end{bmatrix} + \begin{bmatrix} k_S + k_T & -k_T \\ -k_T & k_T \end{bmatrix} \begin{bmatrix} x_S(t) \\ x_T(t) \end{bmatrix} = - \begin{bmatrix} m_S \\ m_T \end{bmatrix} \ddot{x}_g(t). \quad (4)$$

2.2 TMD on a MDOF structure

Assuming the given primary structure (Fig. 2) as a MDOF shear-type building with n storeys (thus, n translational degrees of freedom), under seismic base excitation $\ddot{x}_g(t)$, its equations of motion can be written in a standard way as follows (see e.g. [44]):

$$\mathbf{M}_S \ddot{\mathbf{x}}_S(t) + \mathbf{C}_S \dot{\mathbf{x}}_S(t) + \mathbf{K}_S \mathbf{x}_S(t) = -\mathbf{M}_S \mathbf{r} \ddot{x}_g(t). \quad (5)$$

with typical meaning of symbols involved.

Figure 2. Same as Fig. 1. MDOF shear-type frame primary structure.

As often reported in the literature, see e.g. Villaverde and Koyama [29] and Sadek et al. [28], classical Rayleigh damping is assumed here, specifically by taking the ($n \times n$) damping matrix \mathbf{C}_S as simply proportional to the stiffness matrix \mathbf{K}_S , with:

$$\mathbf{C}_S = \beta \mathbf{K}_S, \quad \beta = \frac{2\zeta_{S,I}}{\omega_{S,I}}, \quad (6)$$

where $\zeta_{S,I}$ and $\omega_{S,I}$ are respectively the given structural damping ratio and computed proper angular frequency of the primary structure referred to its first mode of vibration.

The seismic response of the MDOF structures may be evaluated also in terms of energy indicators, represented here by elastic energy \mathbf{E}_S , kinetic energy \mathbf{T}_S and dissipation power \mathbf{D}_S of the primary structure, which are defined as follows:

$$\mathbf{E}_S(t) = \frac{1}{2} \mathbf{x}_S^T(t) \mathbf{K}_S \mathbf{x}_S(t), \quad \mathbf{T}_S(t) = \frac{1}{2} \dot{\mathbf{x}}_S^T(t) \mathbf{M}_S \dot{\mathbf{x}}_S(t), \quad \mathbf{D}_S(t) = \frac{1}{2} \dot{\mathbf{x}}_S^T(t) \mathbf{C}_S \dot{\mathbf{x}}_S(t). \quad (7)$$

In the case of a MDOF primary structure equipped with a TMD added on top of the top storey (Fig. 2), equations of motion (5) are slightly modified by an added equation and transform (see structure of Eq. (4)) into the following ($n + 1$) equations:

$$\mathbf{M}\ddot{\mathbf{x}}(t) + \mathbf{C}\dot{\mathbf{x}}(t) + \mathbf{K}\mathbf{x}(t) = -\mathbf{M}\mathbf{r}\ddot{x}_g(t). \quad (8)$$

As compared to Eq. (3), in the case of a MDOF primary structure, mass ratio and tuning frequency ratio are defined here as follows [28]:

$$\mu = \frac{m_T}{\Phi_{S,I}^T \mathbf{M}_S \Phi_{S,I}}, \quad f = \frac{\omega_T}{\omega_{S,I}}, \quad (9)$$

where $\Phi_{S,I}$ is the first mode shape of the primary structure, normalized to have a unit component at the top storey [44] and, as stated in Eq. (6), $\omega_{S,I}$ is the fundamental frequency of the primary structure. **Alternative definitions of the mass ratio would be possible. However, the definition in Eq. (9) is quite typical in the literature and it looks sufficient for the present purposes, since it is focused on the first mode of vibration, which is the one to be object of direct control by the single added TMD. The TMD damping ratio is still defined as in Eq. (2).**

2.3 Tuning method and numerical algorithm

The proposed tuning procedure is implemented within MATLAB, where the Minimax optimization method takes advantage of the available *fminimax function* [45]. The goal of this algorithm, developed on a Sequential Quadratic Programming (SQP) method (which is based on a conjugate gradient algorithm), is the minimization of the worst case, in terms of maximum values, of a set of multi-variable functions, starting at an initial estimation, possibly limited by lower and upper bounds on the optimization variables. Besides such choice, tuning results hold independently of the adopted optimization method. Indeed, different optimization *functions* have been tried as well, with the same core algorithm (see Appendix A and relevant flowchart), with similar results.

Within the present context, the Minimax problem, may be stated as:

$$\min_{\mathbf{p}} \max_{\mathbf{R}} \mathbf{R}(\mathbf{p}), \quad \mathbf{l}_b \leq \mathbf{p} \leq \mathbf{u}_b, \quad (10)$$

where \mathbf{p} is the vector of the tuning variables, $\mathbf{R}(\mathbf{p})$ the vector of the objective functions, \mathbf{l}_b and \mathbf{u}_b are the lower and upper bound vectors of the tuning variables.

Here, the goal of the numerical algorithm consists in the minimization of the maximum value of a specific quantity representative of the dynamic response of the structural system, which obviously depends, given the fixed primary structure parameters, on the free TMD parameters. Although in principle the method could allow for the optimization of all three TMD parameters μ , f , ζ_T , the following typical modulus operandi has been adopted: for a given, fixed mass ratio μ , the algorithm seeks the frequency ratio f and the TMD damping ratio ζ_T leading to best tuning. Thus, f and ζ_T are here the two assumed free variables of the optimization process, listed in a (2×1) vector \mathbf{p} .

To start the optimization process, it is necessary to initialize the values of the two variable parameters f and ζ_T . Such a starting point could be provided by well-known tuning formulas from the literature, e.g. those from Den Hartog [9]. However, for the present study a mass ratio $\mu < 10\%$ has been assumed, consistently with engineering applications, which is a threshold that leads to assume $f = 1$, $\zeta_T = 0.1$ as suitable starting values. Numerical tests proved that such choice does not alter significantly the performance of the optimization algorithm, with respect to other options more focused on the specific value of the mass ratio (e.g. from Den Hartog's tuning). The lower and upper bound vectors on the two parameters f and ζ_T are also taken (in MATLAB vector notation) as $\mathbf{l}_b = [0.5; 0.001]$ and $\mathbf{u}_b = [1.5; 1.0]$, which provide quite wide intervals for the optimization process. Further details on the numerical procedure are reported in Appendix A.

The single objective function in Eq. (10) that is finally adopted in all the numerical tests that will be presented in the next sections is a single scalar measure R , which is taken as the Root Mean Square displacement of the top storey of the frame structure, i.e. $R = x_{s,n}^{\text{RMS}}$. The motivations of such choice follow below.

First of all, the considered structures have the common property of displaying a dominant first bending mode of vibration; therefore, the maximum displacement is expected to occur on the top storey. Second, the choice of a RMS indicator assures better efficiency within the optimization process. Indeed, it was experienced in [2], where different response indicators, in type (maximum value vs. RMS average, global vs. local, kinematic index vs. energy value) and location (different floors) have been investigated, that, in case of seismic excitation, an average response quantity, rather than a maximum value, turns-out a better objective function towards tuning. Particularly, the present Minimax optimization converges consistently and with not much difficulties (conversely, the assumption of a maximum value as objective function may bring to convergence complications in some cases). Moreover, one obtains a higher reduction of the global seismic response.

Also, though the objective function taken here regards only the RMS displacement of the primary structure (on the top floor), in [2] it has been observed that RMS velocity and acceleration (on the top floor) are also very suitable objective functions and at similar computational cost. Further experience gained in handling RMS objective functions has been reported in [2], where also the RMS average of the kinetic energy of the primary structure, as defined in Eq. (7), has been considered. It has been demonstrated that this choice could lead to a quite efficient TMD, but implies higher computational cost in the simulations.

Finally, simulations with multi-objective functions have been also performed successfully in the context of canonical loading (thus, no seismic input) [2]. In the present paper, with main focus on demonstrating the concept of optimum tuning at seismic input, only a single-objective function is considered in what follows.

3 Numerical optimization tests at given seismic input

Four series of numerical tests have been carried-out on different prototype shear-type frame buildings taken from the literature [28,29,38]. Both SDOF and MDOF primary structures have been considered. Therefore, besides investigating the validity of the tuning method at given benchmark seismic input, the effectiveness of a TMD vibration control device, in different structural situations, can be preliminary assessed.

First, all buildings are supposed to be subjected to the same benchmark seismic excitation, which is the ELC-180 component of May 19, 1940, Imperial Valley ground motion (recorded at El Centro station), with a time window of dynamic analysis of 40 seconds, a sampling step of 0.01 s and a PGA of about 0.31 g. The choice of this seismic signal as benchmark reference for the present theoretical concept of TMD tuning at seismic input is due to its relevance and frequent adoption in the TMD seismic literature (see e.g. [28]). Nevertheless, various investigations within this framework have been carried-out as well with additional seismic input signals [5], with relevant results that have confirmed the validity of the proposed tuning method, as reported later in Section 4 for three additional seismic input signals.

For each considered structure, results have been organized as follows. Plots of the trends of the optimum TMD parameters f and ζ_T as a function of assumed mass ratio μ are depicted, for a wide range of values of mass ratio delimited by a minimum value of $\mu = 0.0025$ and a maximum value of $\mu = 0.1$, internally spaced as $\Delta\mu = 0.0025$, which basically includes all possible civil engineering applications, where a value of mass ratio $\mu < 0.05$ is generally contemplated, and theoretically even beyond:

$$\mu = [0.0025 : 0.0025 : 0.1]. \quad (11)$$

This interval (again represented in MATLAB notation) allows to provide an exhaustive and accurate representation of the trend of the optimum TMD parameters. Comparisons to typical trends resulting from known literature proposals are displayed as well. Further, optimization process and evaluation of seismic response have been developed for typical values of mass ratio: $\mu = [0.01, 0.02, 0.05, 0.1]$. Here, relevant results are gathered in bar charts for $\mu = 0.05$, where the percentage variation in response reduction with respect to the case with no TMD can be clearly appreciated. The same set of results, but obtained through classical Den Hartog's tuning, are also presented for useful comparison. Specifically, the contents of the bar charts are the following:

- Kinematic response of the main structure in terms of absolute (relative to the ground) displacement, velocity and acceleration of the top storey, referred to both maximum

and average (RMS) values (total accelerations have been computed as well, with similar trends, but not reported in the following);

- Energy response of the main structure in terms of kinetic energy referred to both maximum and average (RMS) values;
- Kinematic response of the Tuned Mass Damper, in terms of maximum value of relative (to the primary structure) displacement, velocity and acceleration.

In the case of the test carried-out on the single-storey building, the optimum TMD parameters have been obtained also through closed-form optimum design formulas proposed in the literature [9, 12, 13, 28, 30]. On the other hand, for the tests carried-out on MDOF structures, only classical Den Hartog's tuning [9] will be considered for comparison purposes, by reading mass and frequency ratios through the first mode of vibration, as outlined in Eq. (9). This *modus operandi* is motivated by the general validity of Den Hartog's tuning, which is actually going to be confirmed by the present numerical results.

3.1 Numerical optimization tests on a SDOF structure

The first numerical tests regard the SDOF frame system proposed by Leung and Zhang [38]. The trends of the obtained optimum TMD parameters evaluated through the proposed method, i.e. optimum frequency ratio and TMD damping ratio, are represented respectively in Fig. 3 and Fig. 4, with comparisons to typical tuning formulas as cited above. The results reported in Figs. 3–4 lead to the following observations.

The optimum frequency ratio f^{opt} in Fig. 3, obtained at seismic input through the present tuning method, displays a trend with higher values with respect to those proposed in the literature. Particularly, the optimum frequency ratio takes values above 1 for $\mu < 0.03$, with a maximum discrete value at around $\mu = 0.01$; then displays decreasing values for $\mu > 0.03$. The minimum distance to the theoretical predictions is found at around $\mu = 0.05$; the maximum distance at near $\mu = 0.01$. The obtained trend appears to be nearer to Asami et al. [30] estimation of best tuning, while the largest difference is recorded with respect to Leung and Zhang [13] prediction. For $\mu < 0.01$ a noticeable increase is achieved, may be due to numerical uncertainties: for a limit case of optimization, i.e. for $\mu \rightarrow 0$, fluctuations of the optimum values may be expected. Corresponding to $\mu = 0.01$, the frequency ratio assumes its highest value, at around 1.03, then it decreases by taking a curvilinear trend until $\mu = 0.05$. For $\mu > 0.05$ the proposed trend assumes a regular decreasing pattern, similar to those coming from the literature. Notice that, to appreciate differences among them, all trends in Fig. 3 are zoomed in a quite tight f^{opt} window between 0.85 and 1.05; less spreadings would be noticed in a typical wider f^{opt} window between 0 and 1.

The proposed optimum TMD damping ratio ζ_T^{opt} in Fig. 4 constantly takes values lower than those obtainable from canonical design formulas, with quite regular increasing trend at increasing μ , that is rather in line with those coming from tuning formulas. In a sense, the new trends of f^{opt} and ζ_T^{opt} on the opposite extremes compensate each other, while leading globally to optimum tuning and attached best reduction of primary structure seismic response. Smaller discrepancies are recorded with respect to almost all predictions, especially with respect to the trends obtained by Leung and Zhang [13] and Asami et al. [30], while a larger difference is obtained from Sadek et al. [28] estimate, which is anyhow a bit far from all other analytical predictions. Indeed, this latter tuning method is based on the idea of implementing high TMD damping ratios, descending from the work of Villaverde and Koyama [29]. The smallest difference is recorded at around

1
2
3
4
5
6
7 $\mu = 0.035$. The trend for $\mu < 0.03$ is reciprocal to that experienced by f^{opt} , with a
8 decrease in ζ_T^{opt} that occurs together with the increase in the f^{opt} estimate. As previously
9 observed for the obtained optimum frequency ratio, the proposed TMD damping ratio
10 takes also a rather irregular trend for $\mu < 0.01$. As a general concluding remark, from
11 the trends of the optimum parameters it appears that the proposed method conceives
12 like optimum a Tuned Mass Damper that is almost resonant with respect to the primary
13 structure (f near 1) and characterized by a quite low damping ratio, especially for small
14 mass ratios ($\mu < 0.05$).
15
16

17 *Figure 3. Optimum frequency ratio as a function of mass ratio (obtained at seismic in-*
18 *put with the proposed method) for the single-storey building ($\zeta_s = 5\%$), with*
19 *comparison to trends from well-known tuning formulas.*
20

21 *Figure 4. Optimum TMD damping ratio as a function of mass ratio (obtained at seismic*
22 *input with the proposed method) for the single-storey building ($\zeta_s = 5\%$), with*
23 *comparison to trends from well-known tuning formulas.*
24
25

26 The results obtained from the numerical tests for mass ratio $\mu = 0.05$ are further
27 reported in Fig. 5. The first apparent observation that can be extracted regarding the
28 kinematic response of the primary structure is the following: consistently with the as-
29 sumed objective function as RMS of the top floor displacement, the response reduction on
30 each RMS quantity is significantly higher than the response reduction achieved on each
31 corresponding maximum quantity. One may observe that, on the maximum values of seis-
32 mic response, the greater reduction is read, as expected, for the displacement values, while
33 velocities and accelerations appear to be less reduced. On the other hand, all the RMS
34 indicators show a remarkable reduction. In short, as expected, the best performance is ob-
35 viously recorded for the RMS displacement, since here it represents the assumed objective
36 function of the optimization process.
37

38 The remarks reported above are valid also on the energy response. Indeed, the effec-
39 tiveness of the Tuned Mass Damper is higher in reducing the RMS energy response vs. the
40 maximum response (for instance, for the assumed $\mu = 0.05$ one can obtain respectively
41 about 45% vs. 25% of response reduction). The parallel comparison to Den Hartog's tun-
42 ing indicates the greater efficiency of the proposed TMD, for all the considered cases and
43 energy response indexes. Surveying the percentage results, one may note that, in general,
44 the effect of the TMD in reducing the seismic response is more sensible on energy response
45 indexes rather than on kinematic response indicators.
46
47

48 The bar charts in Fig. 5 also report explicitly on the achieved reduction in seismic
49 response of the primary structure. It can be noticed that, despite that the present optimum
50 tuning may give optimum values f^{opt} , ζ_T^{opt} that are singularly quite different from classical
51 Den Hartog's best estimates, the final response results are actually very near, with a small
52 gain in response reduction by the present approach. In a sense, the present seismic tuning
53 approach confirms, for the considered seismic input, the validity of Den Hartog's tuning
54 also in the case of seismic input and for frames that display (small) inherent structural
55 damping.
56
57

58 *Figure 5. Seismic response of the single-storey building ($\zeta_s = 5\%$), with or without TMD*
59 *($\mu = 5\%$).*
60

An important issue revealed by the present tuning concept is the dynamic response
of the TMD device, represented in Fig. 5 through its kinematic response, that is read in
terms of relative displacement $x_{TS} = x_T - x_S$, velocity $\dot{x}_{TS} = \dot{x}_T - \dot{x}_S$ and acceleration

1
2
3
4
5
6
7 $\ddot{x}_{TS} = \ddot{x}_T - \ddot{x}_S$ between the Tuned Mass Damper itself and the underneath top storey. In
8 this sense, the most important and noticeable fact is the considerable relative movement.
9 This should be a consequence of the following facts: first of all, the assumed objective
10 function intentionally refers only to the primary structure and does not take into account
11 the dynamic behavior of the TMD; hence, its seismic response has not been optimized (just
12 that of the primary structure). Second, as previously observed in Fig. 4, the optimum TMD
13 is characterized by small damping ratios, thus its kinematic response cannot be damped
14 significantly. This latter situation is also confirmed by the comparison to the response
15 achieved from Den Hartog's tuning, which provides a higher TMD damping ratio: the
16 TMD displays larger movement in the present case of best tuning based on the response
17 of the primary structure only. Indeed, in practical engineering applications, optimum TMD
18 parameters may be intentionally impaired (e.g. TMD damping is increased) to reduce the
19 resulting stroke (TMD displacement relative to its point of attachment to the primary
20 structure) [28, 29, 40].
21
22

23 In general, as expected, best results on response reduction at variable μ are achieved
24 on RMS rather than on maximum values. This is due first to the fact that the assumed
25 objective function is a RMS quantity itself. Nevertheless, the maximum response quanti-
26 ties are also fairly reduced. The increment in terms of TMD effectiveness is much sensible
27 for values of mass ratio $\mu < 0.05$. Indeed, it could be observed that much increase in mass
28 ratio, i.e. from $\mu = 5\%$ to $\mu = 10\%$, does not improve significantly the response reduc-
29 tion. Hence, the best compromise between increase of mass ratio and dynamic response
30 reduction is obtained for $\mu = 0.05$, which is a value that allows for a global reduction
31 of the seismic response of about 40% (Fig. 5). However, also a typical practical value of
32 mass ratio of around 2% is already enough to obtain a considerable reduction in structural
33 response, approximately at around 30%.
34
35

36 Finally, as a sample of the typical time responses recorded in the present numerical
37 analyses, Figs. 6–7 display the seismic response of the primary structure, respectively in
38 terms of floor displacement and kinetic energy, for $\mu = 0.05$. Figs. 6–7 clearly show sig-
39 nificant reduction of seismic response, especially referring to both local peaks and average
40 values. It is interesting to observe that for the very first seconds of seismic event, the
41 TMD is somehow reluctant to sort appreciable effects, most-likely due to its own inertia
42 and viscous damping. However, once activated, the TMD becomes effective in downing
43 the seismic response within the entire duration of the seismic event, with appreciable ef-
44 fects. This appears quite encouraging in supporting the use of TMD devices in seismic
45 engineering applications.
46
47

48 *Figure 6. Kinematic response in terms of displacement of the top storey of the single-storey*
49 *building ($\zeta_S = 5\%$), with or without TMD ($\mu = 5\%$).*

50
51 *Figure 7. Energy response in terms of total kinetic energy of the primary structure of the*
52 *single-storey building ($\zeta_S = 5\%$), with or without TMD ($\mu = 5\%$).*
53
54
55

56 3.2 Numerical optimization tests on MDOF structures

57 In this section, the proposed tuning method is further employed for numerical tests con-
58 cerning shear-type frame MDOF structures equipped with a TMD added on top. Such
59 structures are three shear-type buildings previously studied by Villaverde and Koyama [29]
60 and Sadek et al. [28]: a three-, a six- and a ten-storey building. The frames have differ-
ent inherent damping ratios, as referred to their fundamental mode of vibration, namely
 $\zeta_S = 0$ for the three-storey building (ideal case of no inherent damping), $\zeta_S = 0.05$ for

the six-storey frame and $\zeta_s = 0.02$ for the ten-storey structure. Recall that the damping matrix of each damped structure is assumed to be proportional to the stiffness matrix, as previously described in Section 2.2, Eq. (6). Also, μ and f are read through Eq. (9).

The optimum TMD parameters, i.e. frequency ratio f^{opt} and TMD damping ratio ζ_T^{opt} obtained through the present algorithm are represented respectively in Fig. 8 and Fig. 9 as a function of mass ratio μ , with comparison to those obtained in the previous case of a SDOF primary structure and to those obtainable from Den Hartog's tuning [9]. The quantitative numerical results of the optimization process, for a given typical value of mass ratio ($\mu = 0.05$), are displayed in the form of bar charts in Figs. 10–12. For all these results, the comparison with the outcomes from reference Den Hartog's tuning has been also reported.

The first considerations arising from the achieved results are dedicated to the optimum TMD parameters. Fig. 8 indicates that, for small values of mass ratio μ , the optimum frequency ratio f^{opt} takes values near 1, except for the six-storey building ($\zeta_s = 5\%$), whose values are a bit lower. As the mass ratio increases, in general the frequency ratio slightly decreases, but with different trends for each structure. Considering first the three-storey building ($\zeta_s = 0$), the frequency ratio takes the highest trend, with values above unity for $\mu < 0.04$ and constant decreasing, especially for $\mu > 0.06$. Moreover, a curvilinear trend is obtained for $\mu < 0.02$, similar to that obtained for the single-storey structure.

Figure 8. Optimum frequency ratio as a function of mass ratio (obtained at seismic input with the proposed method) for the various frame buildings, with comparison to trends from reference Den Hartog's tuning.

Figure 9. Optimum TMD damping ratio as a function of mass ratio (obtained at seismic input with the proposed method) for the various frame buildings, with comparison to trends from reference Den Hartog's tuning.

The six-storey building ($\zeta_s = 5\%$) is marked by the lowest values of f^{opt} and a remarkable decrease for $\mu > 0.03$. In the case of the ten-storey building ($\zeta_s = 2\%$), the experienced trend is almost flat, with an average value of around 0.975, meaning that f^{opt} is not that sensitive to μ . In general, it is interesting to note that at increasing structural damping ζ_s , the values of optimum frequency ratio f^{opt} appear to decrease. Indeed, the highest values are displayed by the three-storey building ($\zeta_s = 0$), results for the ten-storey building ($\zeta_s = 2\%$) are placed halfway and outcomes for the six-storey building ($\zeta_s = 5\%$) sit on the lower trend. Notice again that, as in previous Fig. 3, the apparent dissimilar trends of f^{opt} in Fig. 8 are actually inspected in a tight f^{opt} window between 0.85 and 1.05.

Fig. 9 shows that, for very small values of mass ratio, the optimum TMD damping ratio ζ_T^{opt} takes also values near zero. For all the structures, values strongly variable of ζ_T^{opt} are achieved for $\mu < 0.005$, may be due to numerical uncertainties. As the mass ratio increases, the optimum TMD damping ratio also increases, in different ways for each structure: larger values are recorded for the three-storey building ($\zeta_s = 0$), followed by the ten-storey building ($\zeta_s = 2\%$) and the six-storey building ($\zeta_s = 5\%$). Indeed, for instance, by assuming $\mu = 0.10$, for the three structures one obtains respectively a TMD damping ratio of about 17.5%, 13% and 11%. In general, a reasonable possible rule for ζ_T^{opt} can be pointed-out: it appears that the higher the structural damping, the lower the optimum TMD damping ratio. This fact seems to confirm the relevance of structural damping in the context of TMD tuning. Moreover, it can be noticed that all the obtained trends are below that traced by Den Hartog's tuning.

The bar charts results gathered in Figs. 10–12 lead to the comprehensive considerations presented in the following. The kinematic response of the primary structure is considered first. Once again, the effectiveness of the TMD in reducing the seismic response is greater for RMS indicators rather than for max indexes. Particularly, except for the three-storey building that represents a sort of limit case ($\zeta_s = 0$), for the other structures a larger decrease has been obtained for the displacement, as compared to velocity and acceleration. Besides this general consideration, the degree of reduction is variable for the different structures. In fact, the cutting of seismic response of the primary structure is the highest for the three-storey building, a bit lower for the six- and the ten-storey buildings (e.g. for $\mu = 0.05$, reductions of 50–80%, 20–35% and 20–50% are respectively achieved for the three structures). In this context as well, it appears that the relationship between structural damping ratio and TMD efficiency is recovered, as discussed previously for the case of the single-storey building.

The context of energy response confirms somehow the better performance on RMS rather than on max responses. The obtained results remark the significant effectiveness of the TMD against the selected seismic event, in terms of energy response indexes. Besides the limit case of the undamped three-storey building, which is subjected to a huge cut of response, i.e. of about 70–90%, also the six-storey building, with 25–50%, and the ten-storey building, with 30–60% of seismic response decrease take great advantage from the TMD insertion.

The aspect of the considerable kinematic response of the TMD, already detected in the case of the single-storey building, is still visible in this framework, where high levels of TMD response occur. In this sense, Den Hartog's tuning allows for a much limited TMD response, probably because of the larger TMD damping ratio (recall results in Fig. 9).

Figure 10. Seismic response of the three-storey building ($\zeta_s = 0$), with or without TMD ($\mu = 5\%$).

Figure 11. Seismic response of the six-storey building ($\zeta_s = 5\%$), with or without TMD ($\mu = 5\%$).

Figure 12. Seismic response of the ten-storey building ($\zeta_s = 2\%$), with or without TMD ($\mu = 5\%$).

It can be also observed that, for all the three cases, one can recover a situation similar to that previously observed for the SDOF structure: the proposed TMD leads to an effectiveness in reducing the seismic response that is very similar to that achievable in the case of Den Hartog's tuning. Therefore, these results seem to strengthen the validity of Den Hartog's tuning also for a context (damped primary structures subjected to base seismic excitation) that is quite different from that typical of Den Hartog's tuning (undamped primary structure under harmonic point force). On the other hand, these considerations in comparison to Den Hartog's tuning should be further supported by additional studies considering large databases of seismic events. Additional seismic input is first considered next, with similar results. Also, different typologies of structures and possible implications of Eqs. (6) and (9) could be further analyzed.

4 Numerical optimization tests with additional seismic input signals

Given the previous effective analysis based on a single benchmark earthquake record (Imperial Valley 1940), the present section considers three further seismic cases, showing

the robustness of the optimization procedure and the relevant vibration reduction that can be obtained in the presence of a seismic-tuned optimum TMD. The 10-storey shear frame building presented in [29] is assumed here as benchmark primary structure. The strong motions considered in the present analysis are the Kobe (Japan) 1995 earthquake (recorded at the Takarazuka station, 90 component), the L'Aquila (Italy) 2009 earthquake (recorded at the Valle Aterno station) and the Tohoku (Japan) 2011 earthquake (recorded at the Tsukidate station, N-S component). The tuning procedure is successfully applied as earlier, giving rise to results exposed as follows (Table 1, Figs. 13–15).

Table 1. Optimum TMD parameters for the Imperial Valley 1940 (I), Kobe 1995 (K), L'Aquila 2009 (A) and Tohoku 2011 (T) earthquakes, compared to Den Hartog's (DH) tuning parameters, for different values of mass ratio μ .

Figure 13. Seismic response of the ten-storey building ($\zeta_s = 2\%$), with or without TMD ($\mu = 5\%$), Kobe 1995 earthquake.

Figure 14. Seismic response of the ten-storey building ($\zeta_s = 2\%$), with or without TMD ($\mu = 5\%$), L'Aquila 2009 earthquake.

Figure 15. Seismic response of the ten-storey building ($\zeta_s = 2\%$), with or without TMD ($\mu = 5\%$), Tohoku 2011 earthquake.

First, the optimum TMD parameters have been gathered in Table 1, including also the relevant outcomes obtained for the Imperial Valley earthquake considered in the previous section. For the case of the Kobe earthquake, the frequency ratio f^{opt} evaluated with the proposed tuning procedure takes values slightly smaller than those suggested by Den Hartog's tuning, and outlines with those a sort of parallel trend. A similar situation is recovered for the L'Aquila earthquake, even if the parameter f^{opt} decreases much at increasing μ , while for the Tohoku earthquake takes values always at about one, i.e. it approaches the resonance conditions, apparently without dependance on the mass ratio. On the other hand, the optimum TMD damping ratio ζ_T^{opt} is characterized by very similar trends for both the considered seismic input signals, with values again a bit smaller with respect to those obtained by Den Hartog's tuning. However, slightly smaller values are recovered for the Kobe seismic event, while for L'Aquila and Tohoku the parameter ζ_T^{opt} takes almost the same values. In general, it is confirmed the general main trend that provides, at increasing μ , a decreasing f^{opt} and an increasing ζ_T^{opt} . However, this latter TMD parameter appears to assume more regular values, with less sensitivity on the seismic input.

The seismic response reduction, represented in Figs. 13–15, optimally tuned for Kobe 1995, L'Aquila 2009 and Tohoku 2011 earthquakes respectively, provided the following indications. First, by considering the kinematic indices, the peak responses are in general less reduced than the RMS quantities (whose displacement was taken as objective function). Such a fact is more evident for the case of the Kobe and L'Aquila earthquakes, while for the Tohoku seismic input remarkable abatement is obtained also for the peak displacement and velocity. As recovered for the previous seismic event (Imperial Valley 1940), the acceleration is the less reduced among the considered kinematic response quantities. A significant reduction of the kinetic energy is obtained for all the considered earthquakes, in particular for the case of the Tohoku seismic input.

The TMD response, for all the considered kinematic quantities, exhibits again higher values with the proposed tuning method with respect to those coming from Den Hartog's tuning. Such a fact is likely the direct consequence of the proposed TMD optimization,

entirely devoted to the minimization of the primary structure motion only, therefore regardless of the TMD stroke.

The effectiveness of Den Hartog's tuning is confirmed for the three additional earthquake events. The outcomes of these further numerical optimization tests first reiterate the validity of the proposed tuning concept, meaning that the optimum tuning at given seismic input is possible. Then, also remarkable effectiveness of the so-conceived passive TMD is confirmed, in reducing the primary structure seismic response.

In conclusions, the optimization procedure is acknowledged to be effective with these additional seismic signals and, moreover, with further ones [5]. Hence, the robustness of the present theoretical tuning process is assessed at different seismic input.

5 Conclusions

In this work, the concept of TMD tuning at given seismic input has been investigated. A numerical procedure for the systematic optimum tuning of the free TMD parameters towards seismic engineering applications, based on a Minimax algorithm, has been presented. The main feature of the proposed tuning method is the direct application of the algorithm to specific cases of primary structure subjected to selected seismic input signals, so that the tuning of the added TMD turns-out the most efficient for each considered case. The optimization process has been carried-out in the time domain, whereby the seismic response has been evaluated numerically by performing a step-by-step time integration based on the classical Newmark's average acceleration method. A closed loop between time solver and optimization routine has been put in place within a numerical MATLAB environment, which allows to obtain the tuning parameters for best anti-seismic performance. By locating the most appropriate objective function, which finally has been experienced to be a Root Mean Square (RMS) measure, of the displacement of the top floor, the algorithm converges efficiently and rapidly. This work has further proved that, in principle, best tuning at given seismic input is theoretically possible.

The achieved results lead to the following considerations. The proposed optimum TMD parameters in the case of the SDOF primary structure appear to be almost in line with those obtainable from tuning proposals. However, for the assumed reference seismic input signal, the frequency ratio turns-out larger than classical results, while the TMD damping ratio smaller. The proposed TMD allows for a significant reduction of seismic response of the primary structure in the considered case, with respect to the case without TMD, i.e. from a minimum of 20% to a maximum of 50%, depending on the response index. The comparison to Den Hartog's tuning pointed-out very interesting outcomes, since all the obtained results indicate a minimal difference in gain.

The effectiveness of the optimum TMD obtained with the present procedure appears to be confirmed also by the numerical tests performed on MDOF structures. By first considering the results for the case of Imperial Valley earthquake, one may observe that, as the structural damping ratio increases, the value of the optimum TMD damping ratio decreases and, above all, the TMD efficiency in reducing the seismic response decreases. Nevertheless, the so-conceived TMD is demonstrated to be quite efficient, since the structural response is heavily reduced (from 30% for the six-storey structure with $\zeta_s = 0.05$, to 80% for the three-storey building with ideal $\zeta_s = 0$), also in cases of structural damping ratios suitable for real buildings. The considerations outlined above have been somehow confirmed, with little differences, also for the additional considered seismic input signals, from both points of view of optimum TMD parameters and TMD effectiveness in reducing the seismic response.

1
2
3
4
5
6
7 An important feature, that might have practical implications in terms of TMD imple-
8 mentation, is revealed by their dynamic behavior. Indeed, a considerable TMD dynamic
9 response has been recorded. This should be a consequence of two main facts: first of all,
10 the present optimization has been applied (intentionally) to the primary structure only,
11 in view of assessing the maximum theoretical gain of vibration reduction of the primary
12 structure at given seismic input. Second, the optimum values obtained for the TMD
13 damping ratio are relatively small. Thus, the TMD itself might take benefit from a higher
14 TMD damping ratio, so that its dynamic response may also be mitigated, as often adopted
15 in the engineering practice.
16

17 In conclusion, the proposed tuning procedure, which is based on a Minimax numerical
18 algorithm at given seismic input, proves to yield efficient and systematic tuning of the
19 free TMD parameters. In this sense, the choice of an average (RMS) response quantity
20 as objective function allows to optimize effectively the TMD performance all over the
21 time window of analysis (and specifically for strong motion and long duration data), in
22 the context of seismic engineering applications. Most of all, the adopted approach should
23 confirm that, in principle, best tuning at given seismic input is theoretically possible.
24 Moreover, the effectiveness of Den Hartog's tuning appears to be confirmed in the present
25 analyzed seismic context. Despite that only passive TMD devices are considered in this
26 study, these findings should have important theoretical implications also in the context of
27 adaptive, semi-active and active TMDs.
28
29
30

31 Acknowledgements

32 The authors would like to acknowledge public research funding from "Fondi di Ricerca
33 d'Ateneo ex 60%" and a ministerial doctoral grant at the University of Bergamo, Faculty
34 of Engineering (Dalmine), MITIMM Doctoral School.
35
36

37 References

- 38
39
40 [1] E. Rizzi, D. Brescianini, M. Scotti, On the optimal tuning of Tuned Mass Dampers
41 in structural systems, Proc. of 2nd Int. Conf. on Computational Methods in Struc-
42 tural Dynamics and Earthquake Engineering (COMPDYN 2009), Rhodes, Greece,
43 22–24 June 2009, M. Papadrakakis, N.D. Lagaros, M. Fragiadakis (Eds.), Book of
44 Abstracts, p. 254; CD-ROM Proc., CD532, pp. 1–24, 2009.
45
46 [2] J. Salvi, E. Rizzi, Minimax optimization of Tuned Mass Dampers under seismic
47 excitation, Proc. of 8th Int. Conf. on Structural Dynamics (EURODYN 2011),
48 Leuven, Belgium, 4–7 July 2011, G. De Roeck, G. Degrande, G. Lombaert, G. Müller
49 (Eds.), Book of Abstracts, p. 68; CD-ROM Proc., pp. 1892–1899, 2011.
50
51 [3] J. Salvi, E. Rizzi, A numerical approach towards best tuning of Tuned Mass Dampers,
52 Proc. of 25th Int. Conf. on Noise and Vibration Engineering (ISMA 2012), Leuven,
53 Belgium, 17–19 September 2012, P. Sas, D. Moens, S. Jonckheere (Eds.), Book of
54 Abstracts, p. 141; CD-ROM Proc., pp. 2419–2434, 2012.
55
56 [4] J. Salvi, E. Rizzi, E. Rustighi, N.S. Ferguson, Analysis and optimisation of Tuned Mass
57 Dampers for impulsive excitation, Proc. of the 11th Int. Conf. on Recent Advances
58 in Structural Dynamics (RASD 2013), Pisa, Italy, July 1–3, 2013, E. Rustighi (Ed.),
59 Book of Abstracts, p. 64, CD-ROM Proc., Paper ID 1002, pp. 1–15, 2013.
60
[5] J. Salvi, E. Rizzi, M. Gavazzeni, Analysis on the optimum performance of Tuned
Mass Damper devices in the context of earthquake engineering, Proc. of the 9th
Int. Conf. on Structural Dynamics (EURODYN 2014), Porto, Portugal, 30 June–2
July 2014, Paper ID 1872, 8 pages, 2014.

- 1
2
3
4
5
6
7 [6] M.C. Constantinou, T.T. Soong, G.F. Dargush, *Passive Energy Dissipation Systems for Structural Design and Retrofit*, MCEER Monography no. 1, 1998.
- 8
9 [7] J. Ormondroyd, J.P. Den Hartog, The theory of the dynamic vibration absorber, *Journal of Applied Mechanics (ASME)*, 50(7):9–22, 1928.
- 10
11 [8] J.E. Brock, A note on the damped vibration absorber, *Journal of Applied Mechanics (ASME)*, 13(4):A–284, 1946.
- 12
13 [9] J.P. Den Hartog, *Mechanical Vibrations*, McGraw-Hill, 4th edition, 1956.
- 14
15 [10] S.V. Bakre, R.S. Jangid, Optimum parameters of tuned mass damper for damped main system, *Structural Control and Health Monitoring*, 14(3):448–470, 2006.
- 16
17 [11] B. Brown, T. Singh, Minimax design of vibration absorbers for linear damped systems, *Journal of Sound and Vibration*, 330(11):2437–2448, 2011.
- 18
19 [12] S. Krenk, J. Høgsberg, Tuned mass absorbers on damped structures under random load, *Probabilistic Engineering Mechanics*, 23(4):408–415, 2008.
- 20
21 [13] A.Y.T. Leung, H. Zhang, Particle Swarm Optimization of tuned mass dampers, *Engineering Structures*, 31(3):715–728, 2009.
- 22
23 [14] J.C. Miranda, System intrinsic, damping maximized, tuned mass dampers for seismic applications, *Structural Control and Health Monitoring*, 19(9):405–416, 2012.
- 24
25 [15] S. Nagarajaiah, Adaptive passive, semiactive, smart tuned mass dampers: identification and control using empirical mode decomposition, Hilbert transform, and short-term Fourier transform, *Structural Control and Health Monitoring*, 16(7–8):800–841, 2009.
- 26
27 [16] R. Rana, T.T. Soong, Parametric study and simplified design of tuned mass dampers, *Engineering Structures*, 20(3):193–204, 1998.
- 28
29 [17] S.E. Randall, D.M. Halsted, D.L. Taylor, Optimum vibration absorbers for linear damped systems, *Journal of Mechanical Design (ASME)*, 103(4):908–913, 1981.
- 30
31 [18] O.F. Tigli, Optimum vibration absorber (tuned mass damper) design for linear damped systems subjected to random loads, *Journal of Sound and Vibration*, 331(13):3035–3049, 2012.
- 32
33 [19] G.B. Warburton, E.O. Ayorinde, Optimum absorber parameters for simple systems, *Earthquake Engineering and Structural Dynamics*, 8(3):197–217, 1980.
- 34
35 [20] E.O. Ayorinde, G.B. Warburton, Minimizing structural vibrations with absorbers, *Earthquake Engineering and Structural Dynamics*, 8(3):219–236, 1980.
- 36
37 [21] G.B. Warburton, Optimum absorber parameters for minimizing vibration response, *Earthquake Engineering and Structural Dynamics*, 9(3):251–262, 1981.
- 38
39 [22] G.B. Warburton, Optimum absorber parameters for various combinations of response and excitation parameters, *Earthquake Engineering and Structural Dynamics*, 10(3):381–401, 1982.
- 40
41 [23] M. Zilletti, S.J. Elliott, E. Rustighi, Optimisation of dynamic vibration absorbers to minimise kinetic energy and maximise internal power dissipation, *Journal of Sound and Vibration*, 331(18):4093–4100, 2012.
- 42
43 [24] L. Zuo, S.A. Nayfeh, Minimax optimization of multi-degree-of-freedom tuned-mass-dampers, *Journal of Sound and Vibration*, 272(3–5):893–908, 2004.
- 44
45 [25] F. Casciati, F. Giuliani, Performance of Multi-TMD in the Towers of Suspension Bridges, *Journal of Vibration and Control*, 15(6):821–847, 2009.
- 46
47 [26] P. Bisegna, G. Caruso, Closed-form formulas for the optimal pole-based design of tuned mass dampers, *Journal of Sound and Vibration*, 331(10):2291–2314, 2012.
- 48
49
50
51
52
53
54
55
56
57
58
59
60

- 1
2
3
4
5
6
7 [27] J.C. Miranda, On tuned mass dampers for reducing the seismic response of structures, *Earthquake Engineering and Structural Dynamics*, 34(7):847–865, 2005.
- 8
9 [28] F. Sadek, B. Mohraz, A.W. Taylor, R.M. Chung, A method of estimating the param-
10 eters of Tuned Mass Dampers for seismic applications, *Earthquake Engineering and*
11 *Structural Dynamics*, 26(6):617–635, 1997.
- 12
13 [29] R. Villaverde, L.A. Koyama, Damped resonant appendages to increase inherent
14 damping in buildings, *Earthquake Engineering and Structural Dynamics*, 22(6):491–
15 507, 1993.
- 16
17 [30] T. Asami, O. Nishihara, A.M. Baz, Analytical solutions to H_∞ and H_2 optimization
18 of dynamic vibration absorber attached to damped linear systems, *Journal of*
19 *Vibrations and Acoustics (ASME)*, 124(2):284–295, 2002.
- 20
21 [31] G.C. Marano, R. Greco, F. Trentadue, B. Chiaia, Constrained reliability-based
22 optimization of linear tuned mass dampers for seismic control, *International Journal*
23 *of Solids and Structures*, 44(22-23):7370–7388, 2007.
- 24
25 [32] A.M. Kaynia, D. Veneziano, J.M. Biggs, Seismic effectiveness of Tuned Mass Dampers,
26 *Journal of the Structural Division (ASCE)*, 107(8):1465–1484, 1981.
- 27
28 [33] J.R. Sladek, R.E. Klingner, Effect of tuned mass dampers on seismic response,
29 *Journal of the Structural Division (ASCE)*, 109(8):2004–2009, 1983.
- 30
31 [34] C. Sun, S. Nagarajaiah, Study on semi-active tuned mass damper with variable
32 damping and stiffness under seismic excitations, *Structural Control and Health*
33 *Monitoring*, 21(6):890–906, 2014.
- 34
35 [35] K. Kanai, An empirical formula for the spectrum of strong earthquake motions,
36 *Bulletin of the Earthquake Research Institute*, 39(1):85–95, 1961.
- 37
38 [36] N. Hoang, Y. Fujino, P. Warnitchai, Optimal tuned mass damper for seismic ap-
39 plications and practical desing formulas, *Engineering Structures*, 30(3):707–715, 2008.
- 40
41 [37] C.-L. Lee, Y.-T. Chen, L.-L. Chung, Y.-P. Wang, Optimal design theories and
42 applications of tuned mass dampers, *Engineering Structures*, 28(1):43–53, 2006.
- 43
44 [38] A.Y.T. Leung, H. Zhang, C.C. Cheng, Y.Y. Lee, Particle Swarm Optimization of
45 TMD by non-stationary base excitation during earthquake, *Earthquake Engineering*
46 *and Structural Dynamics*, 37(9):1223–1246, 2008.
- 47
48 [39] S. Soheili, M. Abachizadeh, A. Farshidianfar, Tuned mass dampers for earthquake
49 oscillations of high-rise structures using Ant Colony Optimization technique, *Proc. of*
50 *18th Annual Int. Conf. on Mechanical Engineering (ISME 2010)*, Tehran, Iran, 11–13
51 May 2010, pp. 1–6, 2010.
- 52
53 [40] C. Adam, T. Fürtmüller, Seismic Performance of Tuned Mass Dampers, in: H. Irschik,
54 M. Krommer, K. Watanabe, T. Furukawa (Eds.), *Mechanics and Model-Based Con-*
55 *trol of Smart Materials and Structures*, Springer-Verlag, 1st edition, pp. 11–18, 2010.
- 56
57 [41] A. Tributsch, C. Adam, Evaluation and analytical approximation of Tuned Mass
58 Dampers performance in an earthquake environment, *Smart Structures and Systems*,
59 10(2):155–179, 2012.
- 60
[42] G. Bekdaş, S.M. Nigdeli, Estimating optimum parameters of tuned mass dampers
using harmony search, *Engineering Structures*, 33(9):2716–2723, 2011.
- [43] M. Mohebibi, A. Joghataie, Designing optimal tuned mass dampers for nonlinear
frames by Distributed Genetic Algorithms, *The Structural Design of Tall and Special*
Buildings, 21(1):57–76, 2012.
- [44] A.K. Chopra, *Dynamics of Structures - Theory and Applications to Earthquake*
Engineering, Prentice-Hall, 2nd edition, 2001.
- [45] The MathWorks Inc., *MATLAB User's Guide and Optimization Toolbox*, USA, 2011.

Appendix A. Further details on the numerical procedure

The dynamic response of the structural system is computed in the time domain, by integration of the equations of motion through the implicit Newmark's average acceleration method, see e.g. [44]. The Newmark time solver has been linked to a Minimax optimization process in a closed-loop algorithm that allows for optimum tuning at given seismic input. A synoptical flowchart of the tuning algorithm is sketched in Fig. A.1 and can be briefly resumed as follows below.

First, a preliminary analysis is carried-out (initialization): the primary structure parameters are defined, by operating a modal analysis of the main structure and the starting values of the TMD tuning parameters are set, as defined above. A first time integration of the equations of motion gives the initial seismic response. The optimization process is then started. The Minimax algorithm takes control of the iterative procedure by varying the TMD parameters within the chosen admissible bounds and calls iteratively the Newmark time solver to update the system response and to relate it to the previous one. Once all set tolerances on both TMD parameters and response indexes assumed as objective functions are fulfilled, the final optimum TMD parameters are obtained and the corresponding seismic response is recorded. The iterative loops may continue only until when the maximum number of iterations is not exceeded (Fig. A.1).

Figure A.1. Flowchart of the proposed numerical tuning algorithm.

List of Tables

Table 1. Optimum TMD parameters for the Imperial Valley 1940 (I), Kobe 1995 (K), L'Aquila 2009 (A) and Tohoku 2011 (T) earthquakes, compared to Den Hartog's (DH) tuning parameters, for different values of mass ratio μ .

μ	0.01	0.02	0.03	0.05	0.07	0.10
f_I^{opt}	0.957898	0.956986	0.958019	0.955752	0.947851	0.926501
f_K^{opt}	0.977322	0.963653	0.951598	0.929784	0.912712	0.893788
f_A^{opt}	0.995269	0.976977	0.956931	0.926849	0.905619	0.874973
f_T^{opt}	0.996199	0.998503	1.00099	1.00218	0.998433	0.993220
f_{DH}^{opt}	0.990099	0.980392	0.970874	0.952381	0.934579	0.909091
$\zeta_{T,I}^{opt}$	0.0368123	0.0615395	0.0804232	0.106659	0.127375	0.156231
$\zeta_{T,K}^{opt}$	0.0440783	0.0630736	0.0767950	0.0966662	0.110433	0.127288
$\zeta_{T,A}^{opt}$	0.0477160	0.0698723	0.0852191	0.101883	0.115379	0.136223
$\zeta_{T,T}^{opt}$	0.0444066	0.0648976	0.0794594	0.102858	0.113224	0.134765
$\zeta_{T,DH}^{opt}$	0.0609333	0.0857493	0.104510	0.133631	0.156629	0.184637

List of Figures

1	Structural parameters and absolute (relative to the ground) degrees of freedom of a 2DOF mechanical system composed of a SDOF primary structure (S) equipped with a TMD (T) added on top, subjected to seismic base excitation.	3
2	Same as Fig. 1. MDOF shear-type frame primary structure.	4
3	Optimum frequency ratio as a function of mass ratio (obtained at seismic input with the proposed method) for the single-storey building ($\zeta_s = 5\%$), with comparison to trends from well-known tuning formulas.	8
4	Optimum TMD damping ratio as a function of mass ratio (obtained at seismic input with the proposed method) for the single-storey building ($\zeta_s = 5\%$), with comparison to trends from well-known tuning formulas.	8
5	Seismic response of the single-storey building ($\zeta_s = 5\%$), with or without TMD ($\mu = 5\%$).	8
6	Kinematic response in terms of displacement of the top storey of the single-storey building ($\zeta_s = 5\%$), with or without TMD ($\mu = 5\%$).	9
7	Energy response in terms of total kinetic energy of the primary structure of the single-storey building ($\zeta_s = 5\%$), with or without TMD ($\mu = 5\%$).	9
8	Optimum frequency ratio as a function of mass ratio (obtained at seismic input with the proposed method) for the various frame buildings, with comparison to trends from reference Den Hartog's tuning.	10
9	Optimum TMD damping ratio as a function of mass ratio (obtained at seismic input with the proposed method) for the various frame buildings, with comparison to trends from reference Den Hartog's tuning.	10
10	Seismic response of the three-storey building ($\zeta_s = 0$), with or without TMD ($\mu = 5\%$).	11
11	Seismic response of the six-storey building ($\zeta_s = 5\%$), with or without TMD ($\mu = 5\%$).	11
12	Seismic response of the ten-storey building ($\zeta_s = 2\%$), with or without TMD ($\mu = 5\%$).	11
13	Seismic response of the ten-storey building ($\zeta_s = 2\%$), with or without TMD ($\mu = 5\%$), Kobe 1995 earthquake.	12
14	Seismic response of the ten-storey building ($\zeta_s = 2\%$), with or without TMD ($\mu = 5\%$), L'Aquila 2009 earthquake.	12
15	Seismic response of the ten-storey building ($\zeta_s = 2\%$), with or without TMD ($\mu = 5\%$), Tohoku 2011 earthquake.	12
A.1	Flowchart of the proposed numerical tuning algorithm.	17

1
2
3
4
5
6
7
8
9
10
11
12
13
14
15
16
17
18
19
20
21
22
23
24
25
26
27
28
29
30
31
32
33
34
35
36
37
38
39
40
41
42
43
44
45
46
47
48
49
50
51
52
53
54
55
56
57
58
59
60

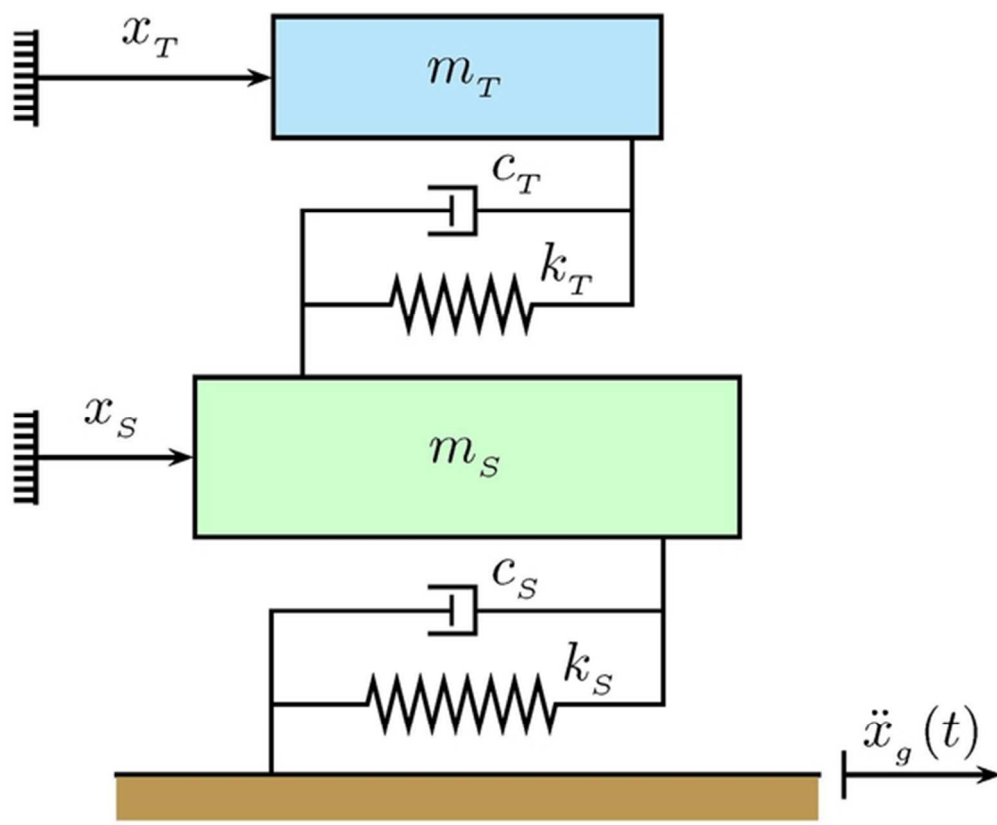

52x42mm (300 x 300 DPI)

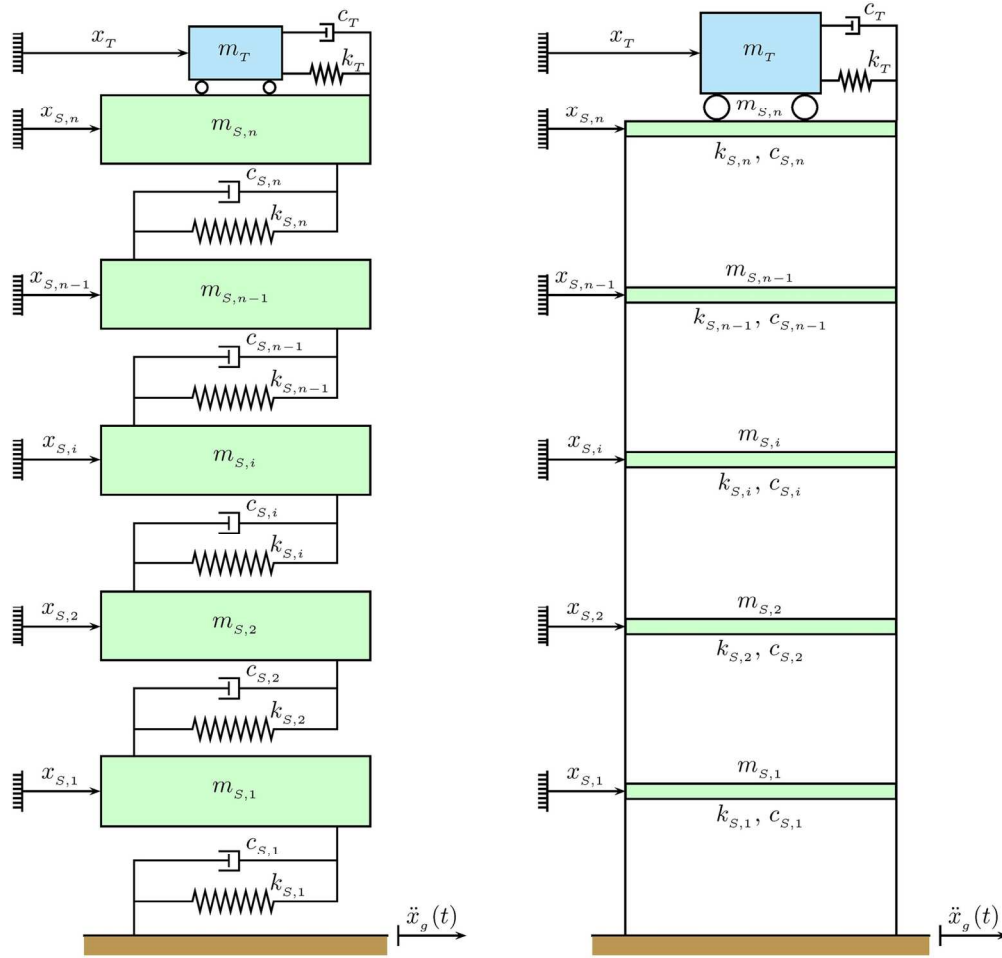

141x135mm (300 x 300 DPI)

1
2
3
4
5
6
7
8
9
10
11
12
13
14
15
16
17
18
19
20
21
22
23
24
25
26
27
28
29
30
31
32
33
34
35
36
37
38
39
40
41
42
43
44
45
46
47
48
49
50
51
52
53
54
55
56
57
58
59
60

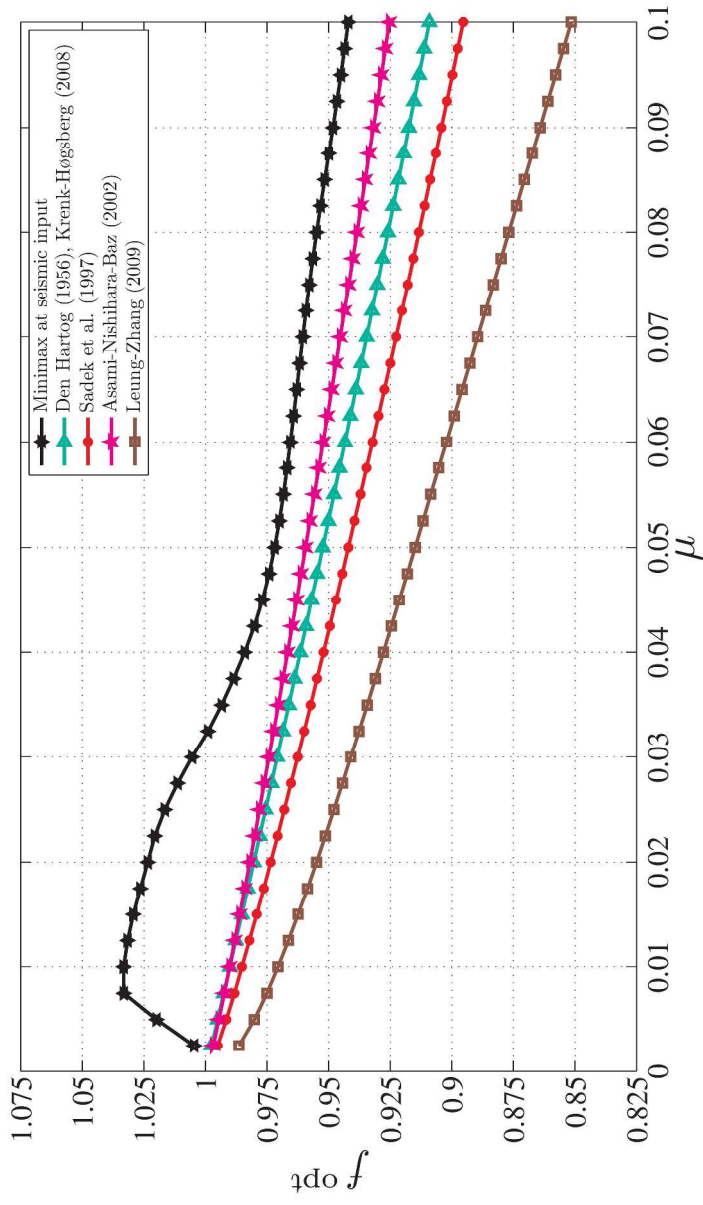

258x437mm (300 x 300 DPI)

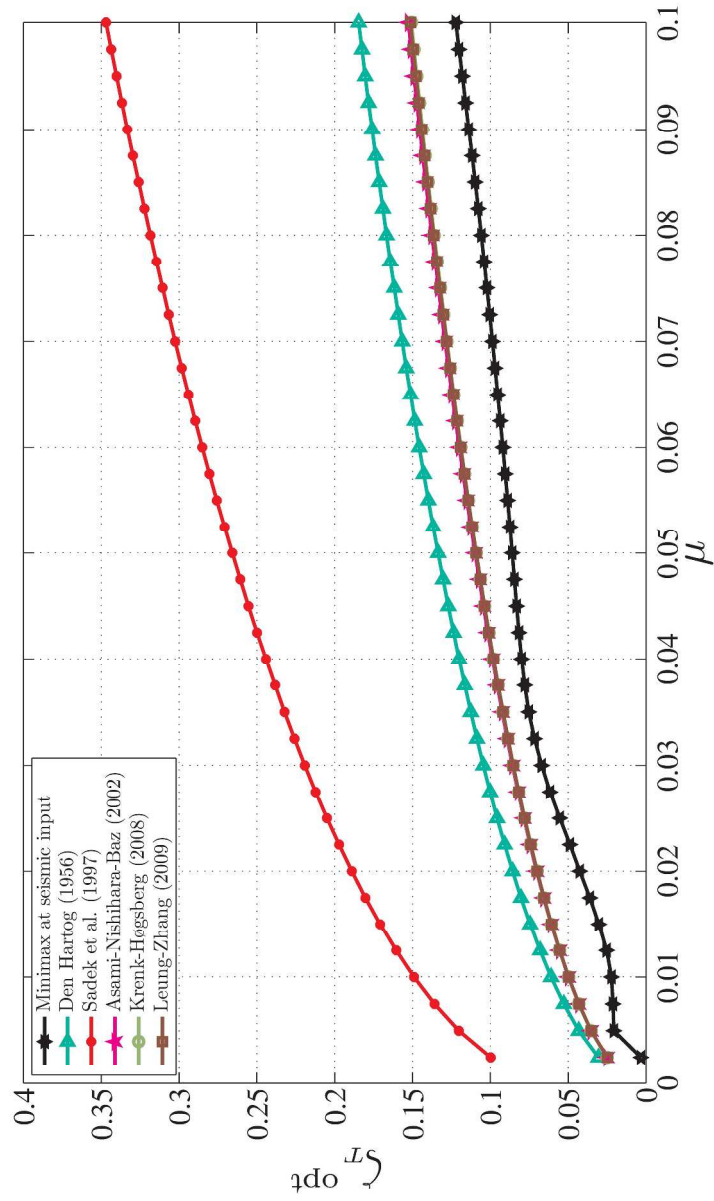

255x427mm (300 x 300 DPI)

1
2
3
4
5
6
7
8
9
10
11
12
13
14
15
16
17
18
19
20
21
22
23
24
25
26
27
28
29
30
31
32
33
34
35
36
37
38
39
40
41
42
43
44
45
46
47
48
49
50
51
52
53
54
55
56
57
58
59
60

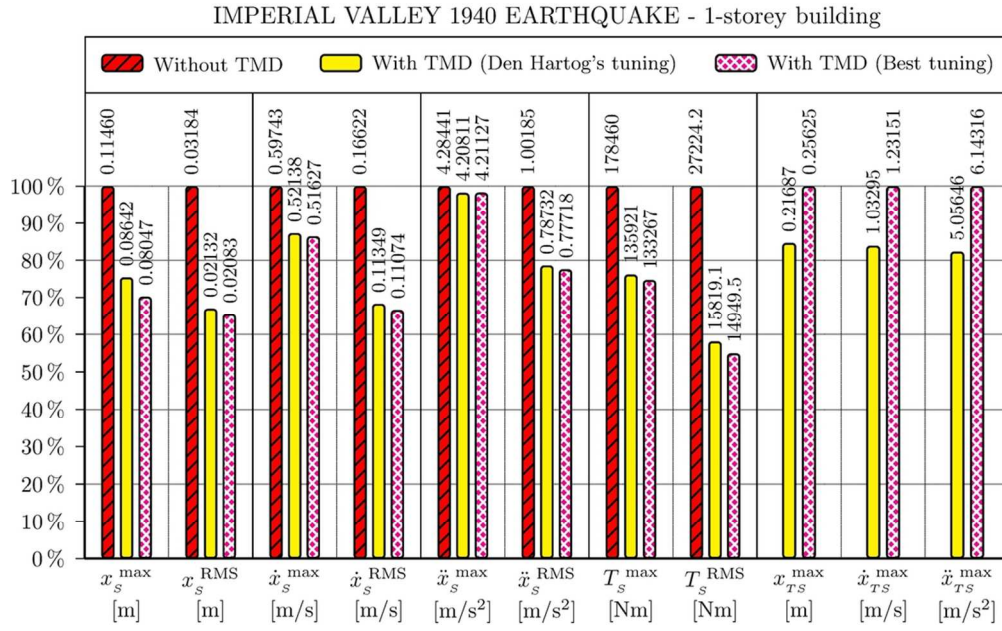

99x61mm (300 x 300 DPI)

Review

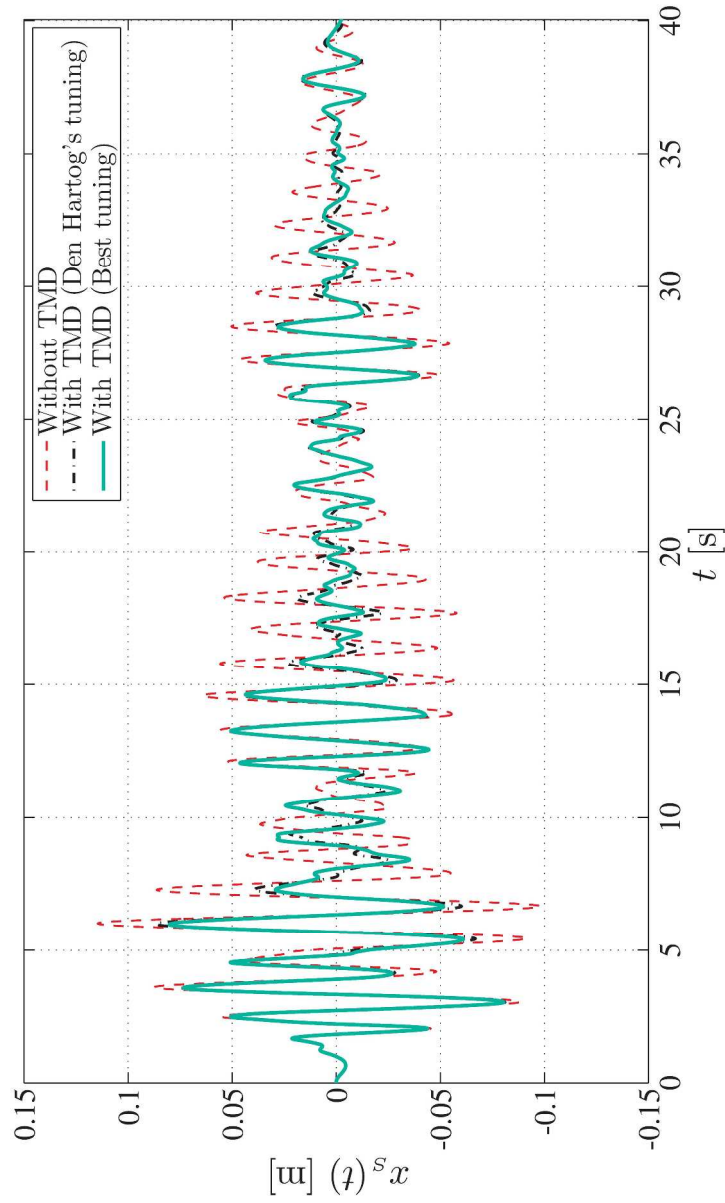

254x420mm (300 x 300 DPI)

1
2
3
4
5
6
7
8
9
10
11
12
13
14
15
16
17
18
19
20
21
22
23
24
25
26
27
28
29
30
31
32
33
34
35
36
37
38
39
40
41
42
43
44
45
46
47
48
49
50
51
52
53
54
55
56
57
58
59
60

1
2
3
4
5
6
7
8
9
10
11
12
13
14
15
16
17
18
19
20
21
22
23
24
25
26
27
28
29
30
31
32
33
34
35
36
37
38
39
40
41
42
43
44
45
46
47
48
49
50
51
52
53
54
55
56
57
58
59
60

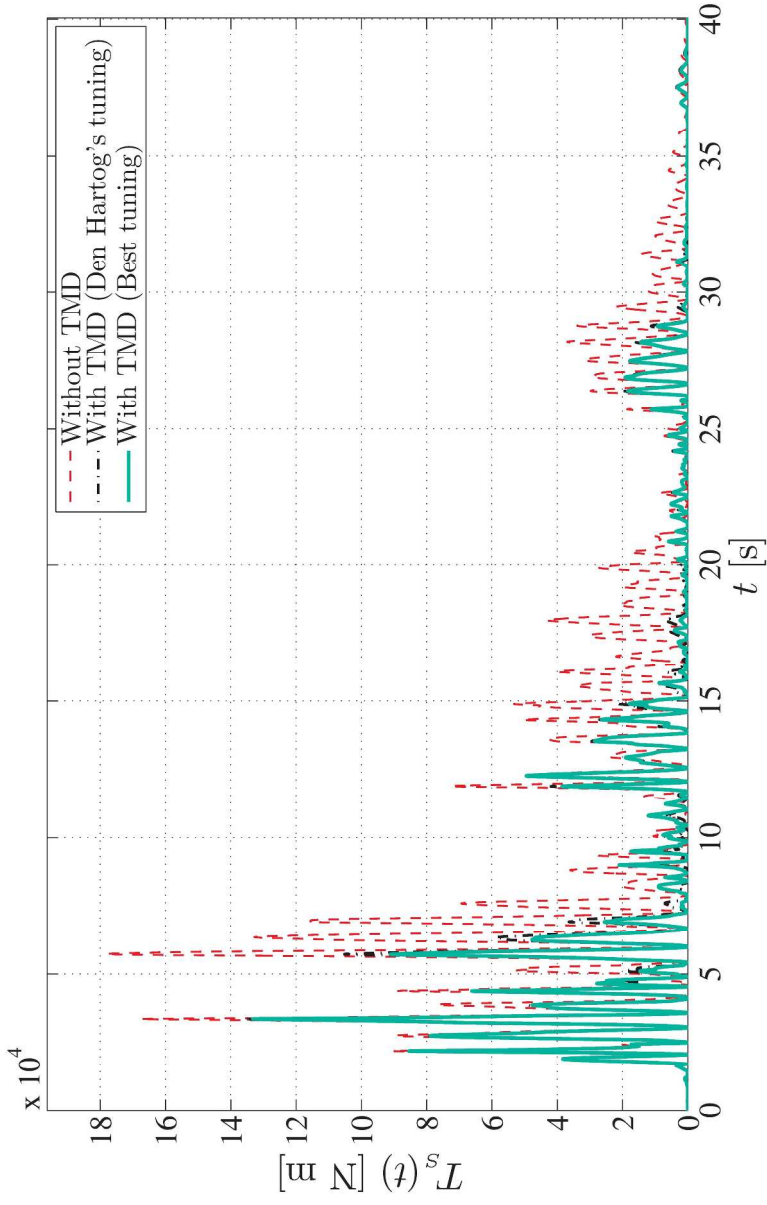

247x384mm (300 x 300 DPI)

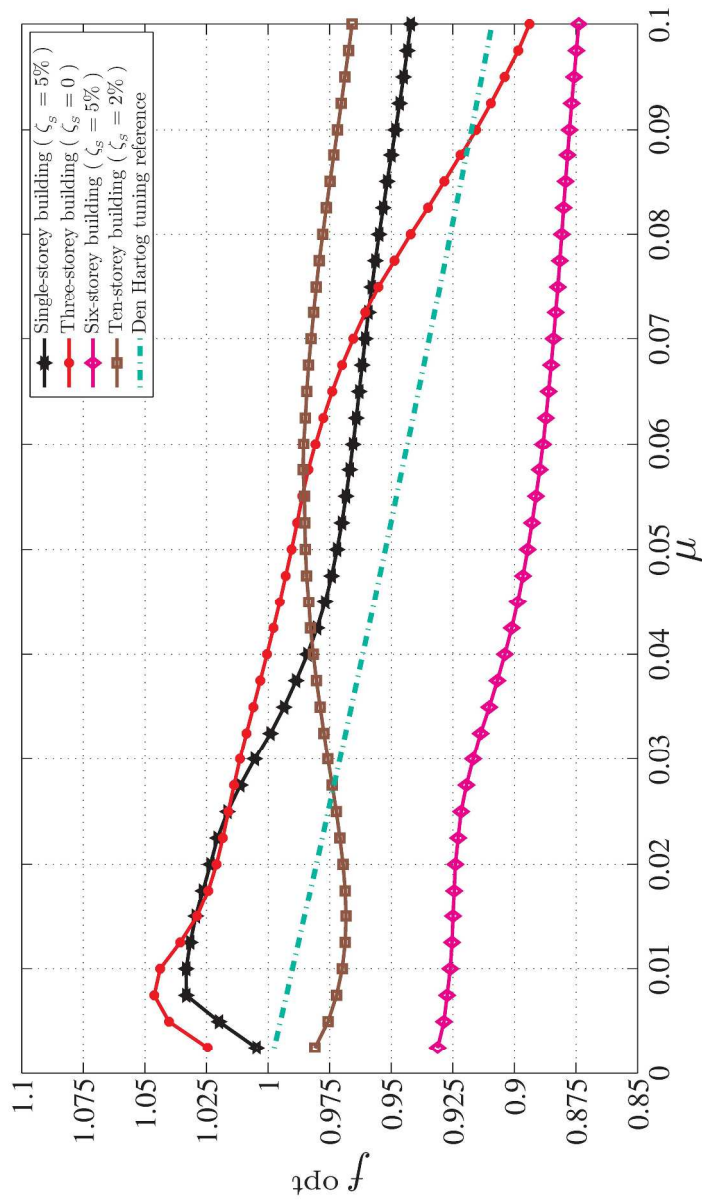

258x437mm (300 x 300 DPI)

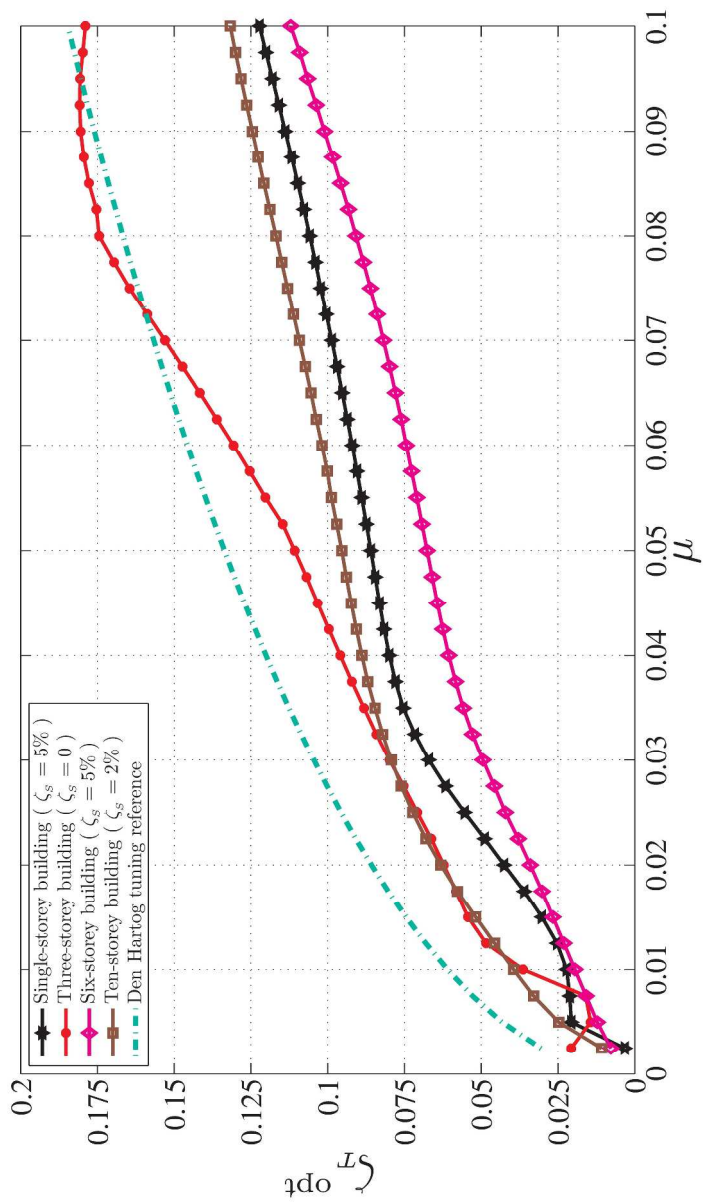

258x438mm (300 x 300 DPI)

1
2
3
4
5
6
7
8
9
10
11
12
13
14
15
16
17
18
19
20
21
22
23
24
25
26
27
28
29
30
31
32
33
34
35
36
37
38
39
40
41
42
43
44
45
46
47
48
49
50
51
52
53
54
55
56
57
58
59
60

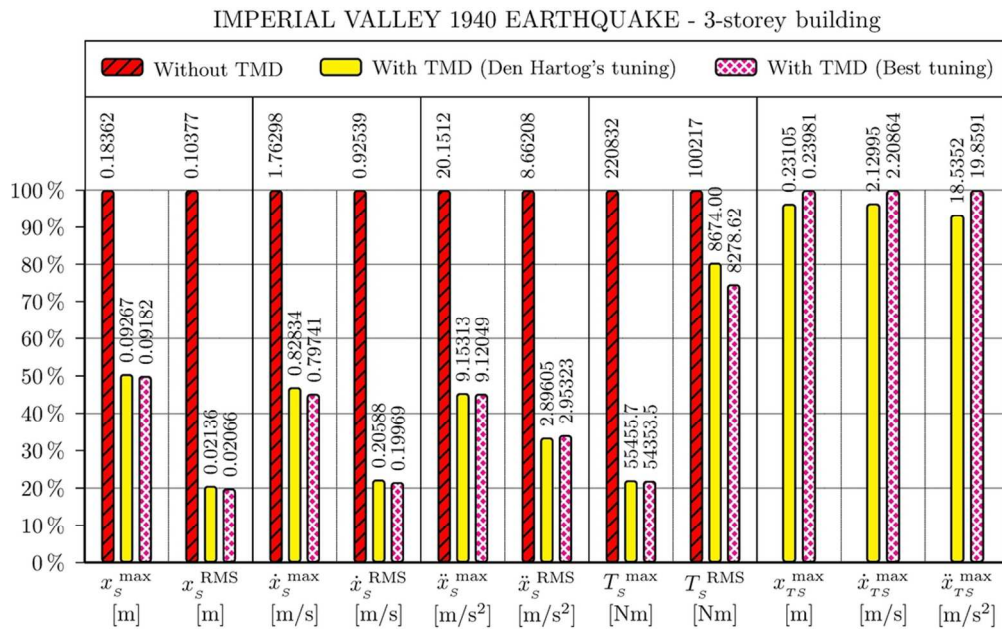

99x61mm (300 x 300 DPI)

IMPERIAL VALLEY 1940 EARTHQUAKE - 6-storey building

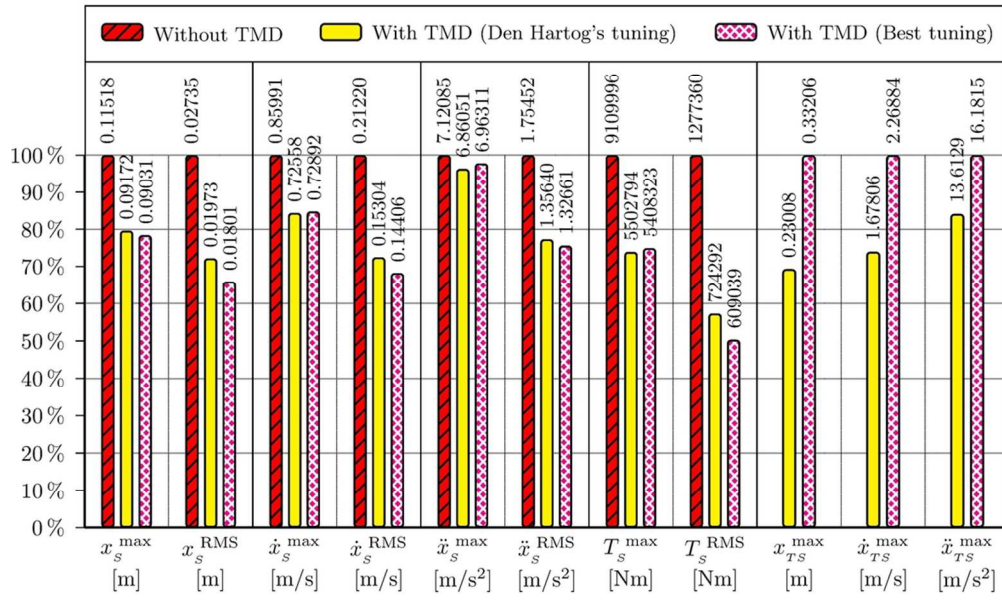

99x61mm (300 x 300 DPI)

Review

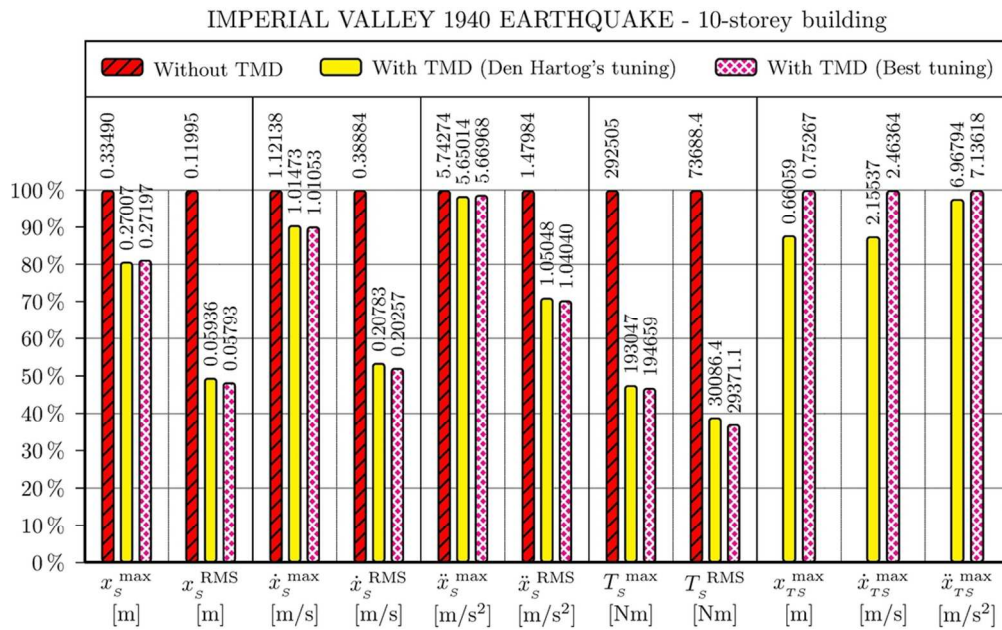

99x61mm (300 x 300 DPI)

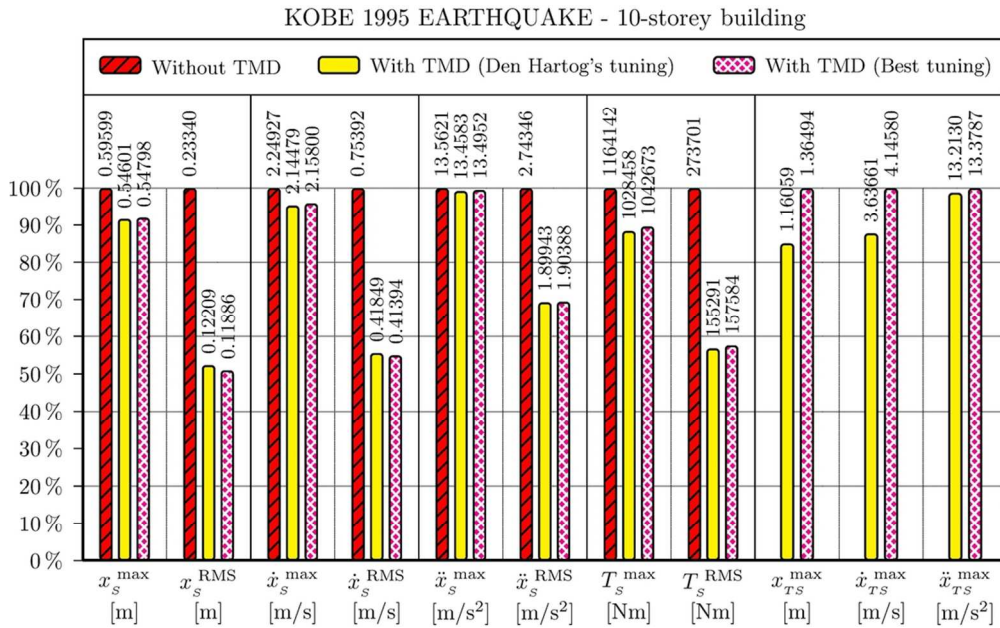

99x61mm (300 x 300 DPI)

L'AQUILA 2009 EARTHQUAKE - 10-storey building

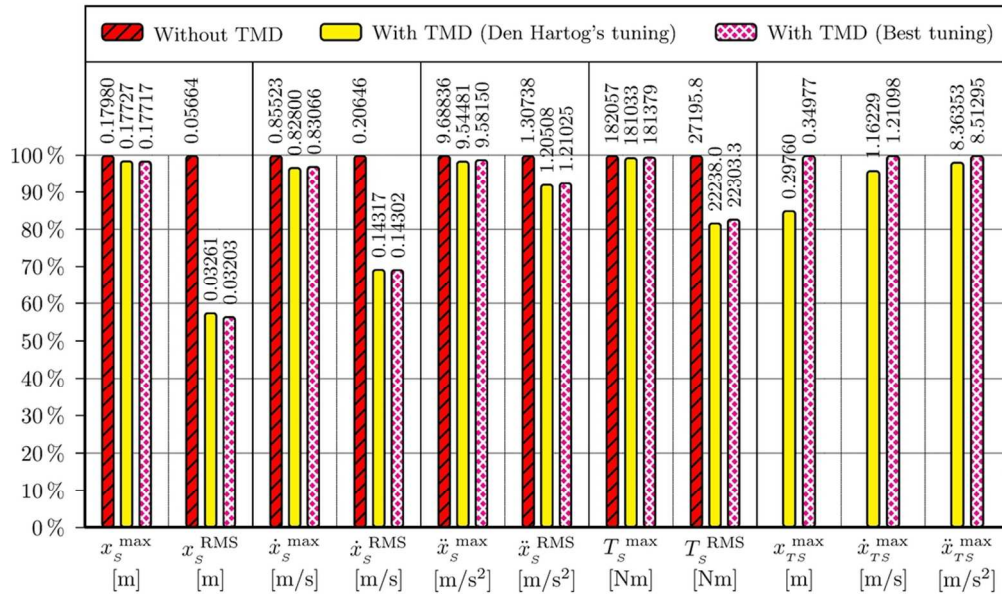

99x61mm (300 x 300 DPI)

Review

TOHOKU 2011 EARTHQUAKE - 10-storey building

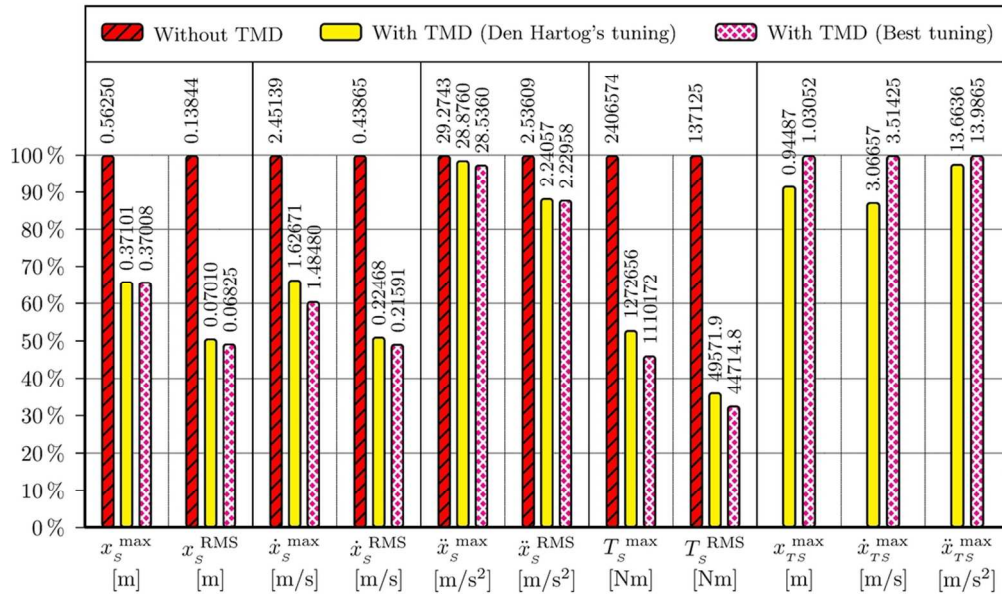

99x61mm (300 x 300 DPI)

Review

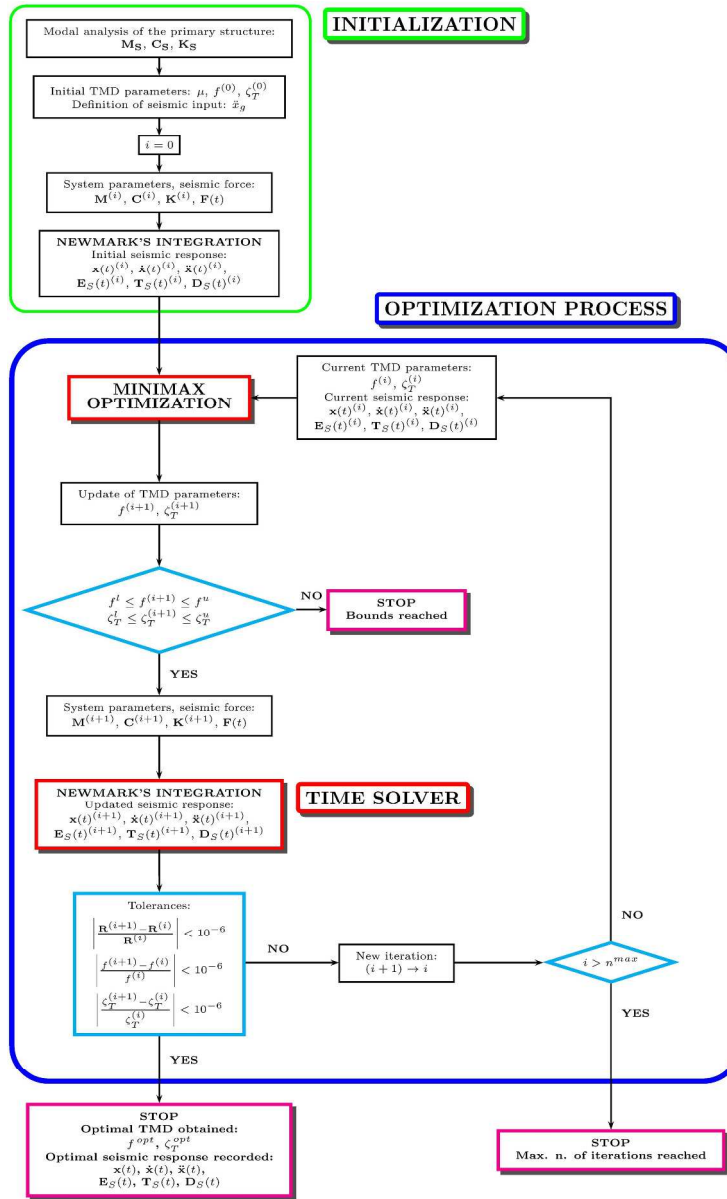

238x387mm (300 x 300 DPI)